



# Federal Register

---

**Wednesday,  
December 2, 2009**

---

## **Part II**

# **Department of Transportation**

---

**National Highway Traffic Safety  
Administration**

---

**49 CFR Parts 571 and 585  
Federal Motor Vehicle Safety Standards,  
Ejection Mitigation; Phase-In Reporting  
Requirements; Proposed Rule**

**DEPARTMENT OF TRANSPORTATION****National Highway Traffic Safety Administration****49 CFR Parts 571 and 585**

[Docket No. NHTSA-2009-0183]

RIN 2127-AK23

**Federal Motor Vehicle Safety Standards, Ejection Mitigation; Phase-In Reporting Requirements**

**AGENCY:** National Highway Traffic Safety Administration (NHTSA), U.S. Department of Transportation (DOT).

**ACTION:** Notice of proposed rulemaking (NPRM).

**SUMMARY:** This notice of proposed rulemaking would establish a new Federal Motor Vehicle Safety Standard (FMVSS) No. 226, to reduce the partial and complete ejection of vehicle occupants through side windows in crashes, particularly rollover crashes. The standard would apply to the side windows next to the first three rows of seats in motor vehicles with a gross vehicle weight rating (GVWR) of 4,536 kilogram (kg) or less (10,000 pounds (lb) or less). To assess compliance, the agency is proposing a test in which an impactor would be propelled from inside a test vehicle toward the windows. The ejection mitigation safety system would be required to prevent the impactor from moving more than a specified distance beyond the plane of a window. To ensure that the systems cover the entire opening of each window for the duration of a rollover, each side window would be impacted at up to four locations around its perimeter at two time intervals following deployment.

The agency anticipates that manufacturers would meet the standard by modifying existing side impact air bag curtains, and possibly supplementing them with advanced laminated glazing. The curtains would be made larger so that they cover more of the window opening, made more robust to remain inflated longer, and made to deploy in both side impacts and in rollovers. In addition, they would be tethered or otherwise designed to keep the impactor within the vehicle.

This NPRM advances NHTSA's initiatives in rollover safety and also responds to Section 10301 of the Safe, Accountable, Flexible, Efficient Transportation Equity Act: A Legacy for Users (SAFETEA-LU). That section directs NHTSA to initiate and complete rulemaking to reduce complete and

partial ejections of vehicle occupants from outboard seating positions, considering various ejection mitigation systems.

**DATES:** You should submit your comments early enough to ensure that the docket receives them not later than February 1, 2010.

**ADDRESSES:** You may submit comments (identified by the Docket ID Number above) by any of the following methods:

- *Federal eRulemaking Portal:* Go to <http://www.regulations.gov>. Follow the online instructions for submitting comments.
- *Mail:* Docket Management Facility: U.S. Department of Transportation, 1200 New Jersey Avenue, SE., West Building Ground Floor, Room W12-140, Washington, DC 20590-0001.
- *Hand Delivery or Courier:* West Building Ground Floor, Room W12-140, 1200 New Jersey Avenue, SE., between 9 a.m. and 5 p.m. ET, Monday through Friday, except Federal holidays.
- *Fax:* 202-493-2251

*Instructions:* For detailed instructions on submitting comments and additional information on the rulemaking process, see the Public Participation heading of the Supplementary Information section of this document. Note that all comments received will be posted without change to <http://www.regulations.gov>, including any personal information provided. Please see the Privacy Act heading below.

*Privacy Act:* Anyone is able to search the electronic form of all comments received into any of our dockets by the name of the individual submitting the comment (or signing the comment, if submitted on behalf of an association, business, labor union, etc.). You may review DOT's complete Privacy Act Statement in the **Federal Register** published on April 11, 2000 (65 FR 19477-78).

*Docket:* For access to the docket to read background documents or comments received, go to <http://www.regulations.gov> or the street address listed above. Follow the online instructions for accessing the dockets.

**FOR FURTHER INFORMATION CONTACT:** For non-legal issues, you may contact Mr. Louis Molino, NHTSA Office of Crashworthiness Standards, telephone 202-366-1740, fax 202-493-2739. For legal issues, you may contact Ms. Deirdre Fujita, NHTSA Office of Chief Counsel, telephone 202-366-2992, fax 202-366-3820.

You may send mail to these officials at the National Highway Traffic Safety Administration, U.S. Department of Transportation, 1200 New Jersey

Avenue, SE., West Building, Washington, DC 20590.

**SUPPLEMENTARY INFORMATION:****Table of Contents**

- I. Executive Summary
- II. Congressional Mandate
- III. Safety Problem
- IV. Proposed Solution
  - a. Various Ejection Mitigation Systems Considered
  - b. Full Window Opening Coverage Is Key
    1. Tests With 50th Percentile Adult Male and 5th Percentile Adult Female Test Dummies
    2. Tests With 6-Year-Old Child Test Dummy Showed a Risk of Ejection Through Openings Not Fully Covered
    3. Differences in Design Between the Two Inflatable Systems
  - c. Comparable Performance in Simulated Rollovers and Component-Level Impact tests
  - d. Advantages of a Component Test Over a Full Vehicle Dynamic Test
  - e. Existing Curtains Can Be Made More Effective
    1. Existing Curtains
    2. Component Tests of Real-World Curtains and Advanced Glazing Systems Show That Improvements Could Be Made
    3. Use of Advanced Glazing With the Air Bag Curtain Resulted in Reduced Displacement
    4. Field Performance of Ejection Mitigation Curtain Systems
- V. Proposed Ejection Mitigation Requirements and Test Procedures
  - a. Impactor Dimensions and Mass
  - b. Displacement Limit (100 mm)
  - c. Speed(s) and Time(s) at Which the Headform Would Impact the Countermeasure.
    1. Ejections Can Occur Both Early and Late in the Rollover Event
    2. Speed at Which Occupants Impact or Move Through the Window Opening
    3. Alternative Testing of Only One Target Position at Higher Speed
  - d. Locations Where the Device Would Impact the Ejection Mitigation Countermeasure To Assess Efficacy
    1. Occupants are Mainly Ejected Through Side Windows
    2. The Requirements Would Apply to Side Windows Adjacent to First Three Rows
    3. Four Targets Per Glazing Area
    4. Method for Determining Impactor Target Locations
  - e. How Should the Window Glazing Be Positioned or Prepared in the Test To Represent Real-World Circumstances?
    1. Window Position and Condition
    2. Window Pre-Breaking Specification and Method
    - f. Test Procedure Tolerances
    - g. Impactor Test Device Characteristics
    - h. Readiness Indicator
- VI. Other Considered Performance Aspects of an Ejection Mitigation Standard
  - a. Rollover Sensor
    1. Introduction
    2. Alternative Approaches
  - b. Quasi-Static Loading in a Compliance Test

- VII. To Which Vehicles Would The Proposed Standard Apply?
- VIII. The Proposed Lead Time and Phase-In Schedules
- IX. The Estimated Benefits and Costs of This Rulemaking
- X. Rulemaking Analyses and Notices
- XI. Public Participation

## I. Executive Summary

Addressing vehicle rollovers is one of NHTSA's highest safety priorities. In 2002, the agency conducted an in-depth review of rollovers and associated deaths and injuries and assessed how NHTSA and the Federal Highway Administration (FHWA) could most effectively improve safety in this area.<sup>1</sup> The agency formulated strategies involving improving vehicle performance and occupant behavior, and with the FHWA taking the lead, improving roadway designs. Vehicle performance strategies included crash avoidance and crashworthiness programs, and included four wide-ranging initiatives to address the rollover safety problem: Prevent crashes, prevent rollovers, prevent ejections, and protect occupants who remain within the vehicle after a crash. Projects aimed at protecting occupants remaining in the vehicle during a rollover included improved roof crush resistance and researching whether seat belts could be made more effective in rollovers.

A major undertaking implementing the first two initiatives was completed in 2007 when NHTSA published a new Federal Motor Vehicle Safety Standard (FMVSS) No. 126 to require electronic stability control (ESC) systems on passenger cars, multipurpose passenger vehicles, trucks, and buses with a gross vehicle weight rating (GVWR) of 4,536 kg (10,000 lb) or less (72 FR 17236, April 6, 2007, Docket 27662). ESC systems use automatic computer-controlled braking of the individual wheels of a vehicle to assist the driver in maintaining control in critical driving situations in which the vehicle is beginning to lose directional stability at the rear wheels (spin out) or directional control at the front wheels (plow out). Because most loss-of-control crashes culminate in the vehicle's leaving the roadway—an event that significantly increases the probability of a rollover—preventing single-vehicle loss-of-control

crashes is the most effective way to reduce deaths resulting from rollover crashes.<sup>2</sup> The agency estimates that when all vehicles (other than motorcycles) under 10,000 lb GVWR have ESC systems, the number of deaths each year resulting from rollover crashes would be reduced by 4,200 to 5,500. Currently, there are over 10,000 such deaths each year.

While ESC systems will avoid many of the roadway departures that lead to rollover, vehicle rollovers will continue to occur.<sup>3</sup> Once a rollover occurs, vehicle crashworthiness characteristics play a crucial role in protecting the occupants. According to agency data, occupants have a much better chance of surviving a crash if they are not ejected from their vehicles. Among the promising technological innovations to prevent occupant ejections are side curtain air bags and improved glazing.

Concurrent with the agency's work on ESC, NHTSA began work on the third initiative on rollover safety, which addresses occupant ejections through side windows in rollovers ("ejection mitigation"). Inroads on this third initiative were realized in 2007 when the agency published a final rule that incorporated a dynamic pole test into FMVSS No. 214, "Side impact protection" (49 CFR 571.214) (72 FR 51908; September 11, 2007, Docket No. NHTSA-29134; response to petitions for reconsideration, 73 FR 32473, June 9, 2008, Docket No. NHTSA-2008-0104).<sup>4</sup> The pole test, applying to motor vehicles with a GVWR of 4,536 kg (10,000 lb) or less, requires vehicle manufacturers to provide side impact protection for a wide range of occupant sizes and over a broad range of seating positions. To meet the pole test,

<sup>2</sup> NHTSA estimates that the installation of ESC will reduce single-vehicle crashes of passenger cars by 34 percent and single vehicle crashes of sport utility vehicles (SUVs) by 59 percent. NHTSA further estimates that ESC has the potential to prevent 71 percent of the passenger car rollovers and 84 percent of the SUV rollovers that would otherwise occur in single-vehicle crashes. NHTSA estimates that ESC would save 5,300 to 9,600 lives and prevent 156,000 to 238,000 injuries in all types of crashes annually once all light vehicles on the road are equipped with ESC systems.

<sup>3</sup> The target population addressed by this rulemaking action is discussed in detail in the Preliminary Regulatory Impact Analysis (PRIA) for this NPRM, which has been placed in the docket for this NPRM.

<sup>4</sup> On August 10, 2005, the "Safe, Accountable, Flexible, Efficient Transportation Equity Act: A Legacy for Users," (SAFETEA-LU), Public Law 109-59 (Aug. 10, 2005; 119 Stat. 1144) was enacted, to authorize funds for Federal-aid highways, highway safety programs, and transit programs, and for other purposes. Section 10302(a) of SAFETEA-LU directed the Secretary to complete the FMVSS No. 214 rulemaking by July 1, 2008. The September 11, 2007 final rule completed the rulemaking specified in § 10302(a).

manufacturers will install new technologies capable of improving head and thorax protection in side crashes, *i.e.*, side curtain air bags and torso side air bags. We believe that these side curtain air bag systems can be effectively modified to meet the occupant containment requirements of this ejection mitigation initiative on rollover safety.

The ejection mitigation initiative was bolstered by the efforts of vehicle manufacturers to install side impact air bags (SIABs) on a voluntary basis. Immediately prior to the publication of the FMVSS No. 214 NPRM, the Alliance of Automobile Manufacturers (the Alliance), the Association of International Automobile Manufacturers, and the Insurance Institute for Highway Safety announced a voluntary commitment to enhance occupant protection in front-to-side crashes, focusing on, among other things, accelerating the installation of SIABs.<sup>5</sup> The industry's voluntary commitment to install side impact air bags demonstrated the feasibility of installing side curtain air bags on a near fleet-wide basis.

Today's NPRM begins a new stage in implementing ejection mitigation. This document would establish a new FMVSS for ejection mitigation (FMVSS No. 226), specifying occupant containment performance requirements. It would apply to motor vehicles with GVWR of 4,536 kg (10,000 lb) or less. The countermeasures most likely to be installed to meet the performance requirements of this NPRM would be the FMVSS No. 214 side curtain air bags<sup>6</sup> made larger to cover more of the window opening, made more robust to remain inflated longer, enhanced to deploy in side impacts and in rollovers, and made not only to cushion but also made sufficiently strong to keep an occupant from being fully or partially ejected through a side window. We have drafted the test procedure of our proposal to accommodate the use of advanced laminated glazing in fixed and

<sup>5</sup> See Docket NHTSA-2003-14623-13. Alliance and AIAM members agreed to provide side impact head protection in at least 50 percent of their new passenger car and light truck fleet by September 1, 2007, and in 100 percent of the vehicles by September 1, 2009.

<sup>6</sup> In this document, this countermeasure is referred to as an "ejection mitigation side curtain air bag," "side curtain air bag," "air bag curtain," "rollover curtain," or simply "curtain." This countermeasure is designed to deploy in a rollover crash and is distinct from strictly a "side impact curtain," which is designed predominately to protect occupants in side crashes and meet the requirements of FMVSS No. 214. Notwithstanding this nomenclature, it is anticipated that rollover curtains will mitigate occupant ejections in side impacts as well as rollover crashes.

<sup>1</sup> The assessment was carried out by one of four Integrated Project Teams (IPTs) formed within NHTSA, whose recommendations culminated in the agency's priority plan, "NHTSA Vehicle Safety Rulemaking and Supporting Research: 2003-2006" (68 FR 43972; July 18, 2003) <http://www.nhtsa.dot.gov/cars/rules/rulings/PriorityPlan/FinalVeh/Index.html>. The IPT Report on Rollover was published in June 2003 (68 FR 36534, Docket 14622).

in possibly moveable windows in addition to or in lieu of the side curtain air bag.

The standard would use a guided impactor component test to assess the ability of the countermeasure (e.g., a curtain system) to mitigate ejections in different types of rollover and side impact crashes involving different occupant kinematics. The test has been carefully designed to represent the dynamic rollover event. The impact mass is based on the mass imposed by a 50th percentile male's upper torso on the window opening during an occupant ejection. The mass of the impactor, 18 kilograms (kg) (40 lb), in combination with the impact speed discussed below, has sufficient kinetic energy to assure that the ejection mitigation countermeasure is able to protect a far-reaching population of people in real world crashes. In the test, the linear travel of the impactor beyond where the device contacts the inside of the unbroken vehicle glazing must not exceed 100 millimeters. This displacement limit serves to control the gap size between the countermeasure and the window opening, thus reducing the potential for both partial and complete ejection of an occupant.

To evaluate the performance of the curtain to fully cover potential ejection routes, the impactor would typically target four specific locations per side window adjacent to the first three rows of the vehicle. NHTSA has tentatively determined that impacting four targets around the perimeter of the opening would assure that the window will be covered by the curtain, while imposing a reasonable test burden. Small windows would be tested with fewer targets.

Computer modeling has shown that ejections can occur early and late in the rollover event. The impactor would strike the targets at two impact speeds and at two different points in time following side curtain air bag deployment, to ensure that the curtains will retain the occupant from the relatively early through the late stages of a rollover. The first impact would be a 24 kilometer per hour (km/h) (15 miles per hour (mph)) impact, 1.5 seconds after deployment of the curtain. The 1.5 second time delay is proposed because half of all fatal complete ejections occurred in crashes with 5 or more quarter-turns ( $\frac{1}{4}$ -turns), and film analysis of vehicles that rolled 5 or more  $\frac{1}{4}$ -turns in staged rollover tests performed by the agency showed the vehicles taking about 1.5 seconds to achieve one complete vehicle revolution. The second impact would be at 16 km/h (10 mph), 6 seconds after

deployment of the curtain. Film analysis of the staged vehicle tests showed a maximum roll time of 5.5 seconds for a vehicle that rolled 11  $\frac{1}{4}$ -turns. The test speeds are representative of the occupant dynamics during the rollover events as well as side impacts. The agency is considering the alternative of applying the 24 km/h (1.5 second delay) impact only to the target location that exhibited the greatest displacement in the 16 km/h (6 second delay) impact.

Under today's NPRM, vehicle manufacturers would have to provide information to NHTSA upon request that describes the conditions under which the ejection mitigation air bags will deploy. We do not believe conditions need to be specified in the standard dictating when the sensors should deploy; field data indicate that rollover sensors are deploying when they should in the real world. We discuss our rationale for this decision in more detail below. Comments are requested on this issue.

## II. Congressional Mandate

Section 10301 of SAFETEA-LU required the Secretary to issue by October 1, 2009, an ejection mitigation final rule reducing complete and partial ejections of occupants from outboard seating positions. Section 10301 of SAFETEA-LU amended Subchapter II of chapter 301 (the National Traffic and Motor Vehicle Safety Act, 49 U.S.C. Chapter 301) to add § 30128. Paragraph (a) directs the Secretary to initiate rulemaking proceedings, for the purpose of establishing rules or standards that will reduce vehicle rollover crashes and mitigate deaths and injuries associated with such crashes for motor vehicles with a gross vehicle weight rating of not more than 10,000 pounds. Paragraph (c) directs the Secretary to initiate a rulemaking proceeding to establish performance standards to reduce complete and partial ejections of vehicle occupants from outboard seating positions. Paragraph (c) states that, in formulating the standards, the Secretary shall consider various ejection mitigation systems, and that the Secretary shall issue a final rule under this paragraph no later than October 1, 2009. Paragraph (e) states that if the Secretary determines that the subject final rule deadline cannot be met, the Secretary shall notify and provide explanation to the Senate Committee on Commerce, Science, and Transportation and the House of Representatives Committee on Energy and Commerce of the delay. On September 24, 2009, the Secretary provided appropriate notification to Congress that the final

rule will be delayed until January 31, 2011.

## III. Safety Problem

Rollover crashes are a significant and a particularly deadly safety problem. As a crash type, rollovers are second only to frontal crashes as a source of fatalities in light vehicles. According to 1998–2007 Fatal Analysis Reporting System (FARS) data, frontal crash fatalities have averaged about 12,000 per year, while rollover fatalities have averaged 10,400 per year. In 2007, 35 percent of all fatalities were in rollover crashes. Since the early 1990s, the sport utility vehicle (SUV) segment has provided an increasing proportion of rollover fatalities. There were approximately 1,700 SUV rollover fatalities in 1998, and more than 2,800 in 2007. The last 10 years of data from the National Automotive Sampling System (NASS) General Estimates System (GES) indicate that an occupant in a rollover is 14 times more likely to be killed than an occupant in a frontal crash.<sup>7</sup>

Ejection is a major cause of death and injury in rollover crashes. According to 1998–2007 FARS data, about half of the occupants killed in rollovers were completely ejected from their vehicle. During this time period, there were 338 fully ejected occupants killed for every 1,000 fully ejected occupants in rollover crashes, as compared to 14 of every 1,000 occupants not fully ejected occupants killed.<sup>8</sup> Although the majority of occupants exposed to rollover crashes are in vehicles that roll two  $\frac{1}{4}$ -turns or less, the distribution of ejected occupants who are seriously injured (maximum abbreviated injury scale (MAIS) 3+) or killed is skewed towards rollovers with higher degrees of rotation. According to NASS Crashworthiness Data System (CDS) data of occupants exposed to a rollover crash from 1988 to 2005, half of all fatal complete ejections occurred in crashes with five or more  $\frac{1}{4}$ -turns.

Annualized injury data from 1997 to 2005 NASS CDS and fatality counts adjusted to 2005 FARS levels indicate that ejection through side windows constitutes the greatest part of the ejection problem. There were 6,174 fatalities, 5,271 MAIS 3–5 injuries, and 18,353 MAIS 1–2 injuries for occupants

<sup>7</sup> The relative risk of fatality for each crash type can be assessed by dividing the number of fatalities in each crash type by the frequency of the crash type. The frequency of particular crash types is determined by police traffic crash reports (PARs).

<sup>8</sup> The data combines partially-ejected and un-ejected occupants together, because partial ejection is sometimes difficult to determine and the PAR-generated FARS data may not be an accurate representation of partially-ejected occupant fatalities.

ejected through side windows. These constitute 61 percent of all ejected fatalities, 47 percent of MAIS 3–5 injuries, and 68 percent of MAIS 1–2 injuries.

This NPRM seeks to reduce complete and partial ejections of occupants from outboard seating positions in crashes involving a rollover or a side planar crash. The target population for this rulemaking would not include the population addressed by the FMVSS No. 214 pole test rulemaking.<sup>9</sup> The target population would also not include persons benefited by the installation of ESC systems in vehicles, based on an assumption that all model year 2011 vehicles would be equipped with ESC. As adjusted, the target population for this ejection mitigation rulemaking is 1,392 fatalities, 1,410 MAIS 3–5 injuries and 4,217 MAIS 1–2 injuries. This target population constitutes 23% of fatally-injured occupants ejected through the side window, 27% of MAIS 3–5 injured, and 23% of MAIS 1–2 injured side window-ejected occupants.

#### IV. Proposed Solution

##### a. Various Ejection Mitigation Systems Considered

In formulating this NPRM, NHTSA considered various ejection mitigation systems in accordance with Section 10301 of SAFETEA–LU. One of the considered systems was advanced laminated side glazing, a countermeasure thought in the 1990s to have potential for use in ejection mitigation.<sup>10</sup> In 2002, the agency terminated an advance notice of proposed rulemaking on advanced glazing after observing that advanced glazing appeared to increase the risk of neck injury by producing higher neck shear loads and neck moments than impacts into tempered side glazing (67 FR 41365, June 18, 2002). In addition, the estimated incremental cost for installing ejection mitigation glazing in front side windows ranged from over \$800 million to over \$1.3 billion, based on light vehicle annual sales of 17

million units in the 2005–2006 timeframe. Moreover, because side curtain air bags were showing potential as an ejection mitigation countermeasure, NHTSA redirected its research and rulemaking efforts toward developing performance-based test procedures for an ejection mitigation standard.<sup>11</sup>

As with all of the FMVSSs, this proposed ejection mitigation standard would be performance-oriented, to provide manufacturers wide flexibility and opportunity for design innovation in developing countermeasures that could be used for ejection mitigation. We anticipate that manufacturers would likely install ejection mitigation side curtain air bags in response to this rulemaking, taking advantage of the side impact curtains already in vehicles. However, advanced glazing could have a role in complementing ejection mitigation curtain systems. NHTSA tested several vehicles' ejection mitigation side curtain air bags both with and without laminated glazing to the 18 kg impactor performance test proposed in this NPRM. In the tests, the glazing was pre-broken to simulate the likely condition of the glazing in a rollover. Tests of vehicles with advanced glazing resulted in an average 51 mm reduction in impactor displacement across target locations.<sup>12</sup> That is, optimum (least) displacement of the headform resulted from use of both an ejection mitigation window curtain and advanced glazing. To encourage manufacturers to enhance ejection mitigation curtains with advanced glazing, this NPRM proposes to allow windows of advanced laminated glazing to be in position, but pre-broken to reproduce the state of glazing in an actual rollover crash. Although the glazing is pre-broken, the laminate in combination with the remaining integrity of the glazing acts as a barrier to ejection. Details on the pre-breaking method are given later in this preamble. As discussed later, the vast majority of side windows in real-world rollover crashes are closed.<sup>13</sup>

Comments are requested on whether manufacturers would use advanced glazing or some other novel window design alone, without a window curtain, to meet the ejection mitigation requirements throughout the vehicle or at least for some windows (e.g., as the countermeasure to protect against ejection from a small window). Pre-breaking the glazing using the proposed methodology would substantially damage advanced glazing and might foreclose its use to meet the proposed requirements. NHTSA's (limited) test data, discussed below, indicate that various combinations of ejection mitigation countermeasures do not have a high potential for producing neck injury.<sup>14</sup> Yet, in lateral impact tests comparing unbroken advanced glazing alone to tempered glazing, the agency found that in some tests the lateral neck shear forces were higher for the advanced glazing.<sup>15</sup> Given these data, comments are requested on the potential for neck injury in the event that advanced glazing alone were used to comply with the proposed standard.

##### b. Full Window Opening Coverage Is Key

NHTSA undertook several research programs using a dynamic rollover fixture (DRF), which produced full-dummy ejection kinematics in an open window condition, to assess the potential effectiveness of ejection mitigation countermeasures in a rollover.<sup>16</sup> These countermeasures

69 percent of the time. However, we are concerned that for those instances where manufacturers utilize advanced (laminated) glazing in their design, when the window is partially or fully down, there may be a reduction of occupant retention. As discussed later in this preamble, comments are requested on alternatives to the approach of allowing laminated windows to be in place and pre-broken. One option would be to test with all movable windows removed or rolled down, regardless of whether the window is laminated.

<sup>14</sup> "Status of NHTSA's Ejection Mitigation Research Program," Willke *et al.*, 18th International Technical Conference on the Enhanced Safety of Vehicles, paper number 342, June 2003.

<sup>15</sup> "Ejection Mitigation Using Advanced Glazing, Final Report," *supra*.

<sup>16</sup> NHTSA developed the DRF to produce full-dummy ejection kinematics in a less costly manner than full-scale testing. The DRF models a lateral rollover crash of approximately one vehicle revolution. The DRF rotates approximately one revolution and comes to rest through the application of a pneumatic braking system on one end of the pivot axle. It does not simulate lateral vehicle accelerations often encountered in a rollover crash prior to initiation of the rollover event. The DRF has a test buck fabricated from a Chevrolet CK pickup cab. The cab was longitudinally divided down the center from the firewall to the B-pillar. The left (driver) side is rigidly attached to the test platform. The Chevrolet CK was chosen so that the advanced glazing systems developed in the previous ejection

<sup>9</sup> The Phase 1 FMVSS No. 214 rulemaking included reduction of partial side window-ejected adult (13+ years) occupants in side impacts, but did not include complete ejections. The Phase 1 rulemaking also excluded any impact where a rollover was the first event. Crashes where a rollover was a subsequent event were included, but only for partially-ejected fatalities. In addition, benefits were only assumed for side impact crashes with  $\Delta V$  between 19.2 and 40.2 km/h (12 to 25 mph) and impact directions from 2 to 3 o'clock and 9 to 10 o'clock.

<sup>10</sup> Ejection mitigation glazing systems have a multi-layer construction with three primary layers. There is usually a plastic laminate bonded between two pieces of glass.

<sup>11</sup> "Ejection Mitigation Using Advanced Glazing, Final Report," NHTSA, August 2001, DMS Docket 1782–22 ("advance glazing final report").

<sup>12</sup> To accompany this NPRM, NHTSA prepared a technical analysis that presents a detailed analysis of engineering studies, and other information supporting the NPRM, such as the results of NHTSA's impactor testing of OEM and prototype side window ejection mitigation systems. "Technical Analysis in Support of a Notice of Proposed Rulemaking for Ejection Mitigation." We will refer to this technical analysis from time to time in this preamble. A copy of the technical analysis has been placed in the docket.

<sup>13</sup> For the target population of this rulemaking, the front row window through which an occupant was ejected was closed or fixed prior to the crash

included several designs of inflatable curtain air bags, advanced laminated glazing, and combinations of curtains and advanced glazing. The results showed, however, that not all ejection mitigation air bag curtains work the same way. Full window opening coverage is key to the effectiveness of the curtain in preventing ejection.

#### 1. Tests With 50th Percentile Adult Male and 5th Percentile Adult Female Test Dummies

In the first research program, experimental roof rail-mounted inflatable devices developed by Simula Automotive Safety Devices (Simula) and by TRW were evaluated on the DRF, along with an advanced side glazing system.<sup>17</sup> In the tests, unrestrained 50th percentile male and 5th percentile female Hybrid III dummies, instrumented with 6 axis upper neck load cells and tri-axial accelerometers in the head, were separately placed in the buck.<sup>18</sup> The DRF rotation results in a centripetal acceleration of the dummy that caused it to move outwards towards the side door/window. In baseline tests of the unrestrained dummies in the DRF with an open side window and no countermeasure, the dummies were fully ejected. The ability of the countermeasure to restrain the dummies was assessed and compared to that baseline test.

In the tests of the experimental inflatable devices, the air bags were pre-deployed and their inflation pressure was maintained throughout the test by the use of an air reservoir tank mounted on the platform.<sup>19</sup> In the tests, the dummy's upper body loaded the inflatable device, which limited the dummy's vertical movement toward the roof and caused the pelvis to load the

mitigation research could be evaluated in this program. A seat back and cushion were made from Teflon material, to minimize the shear forces on the dummy buttocks for more desired loading on the window area by the dummy's head and upper torso.

<sup>17</sup> "Status of NHTSA's Ejection Mitigation Research Program," Willke *et al.*, 18th International Technical Conference on the Enhanced Safety of Vehicles, paper number 342, June 2003.

<sup>18</sup> Two dummy positions were used. The first was behind the steering wheel. The second position was more inward, toward the pivot axle, which generated higher contact velocities. Film analysis was used to measure the dummy's relative head contact velocity with the side window plane from these two seating positions. From the first position, the impact speeds were 14 km/h (9 mph) for the 5th percentile female dummy and 18 km/h (11 mph) for the 50th male. From the second (inboard) position, the velocities were 31 km/h (19 mph) for the 5th female and 29 km/h (18 mph) for the 50th male.

<sup>19</sup> Since these were experimental systems, they were not deployed through pyrotechnic or in-vehicle compressed gas, as might be the case with production designs. The air pressure supplied by the laboratory reservoir kept the systems fully inflated over the test period.

side door throughout the roll, rather than to ride up the door. The inflatable devices contained the torso, head, and neck of the dummy, so complete ejection did not occur. However, both devices did allow partial ejection of the dummy's shoulder and arm below the bags, between the inflatable devices and the vehicle door.

In the test of the advanced side glazing (laminated with door/window frame modifications around the entire periphery to provide edge capture), the glazing contained the dummies entirely inside the test buck. The glazing was not pre-broken before the testing. There was some flexing of the window frame when the dummies loaded the glazing, and the 50th percentile male dummy's shoulder shattered the glass when the dummy was located behind the steering wheel.

In the test of the combined systems, the dummies remained entirely inside the buck. Although the shoulder and arm escaped under the inflatable devices, the advanced glazing prevented the partial ejection seen in tests of the inflatable devices alone.

In these tests, the ejection mitigation systems did not show a high potential for producing head and neck injury. However, head and neck loading were higher than the open window condition. The highest load with respect to the Injury Assessment Reference Values (IARVs) was 82 percent for the neck compression for the 5th percentile female tested with the Simula/laminate combination. The highest injury response for the 50th percentile male dummy was 59 percent for the neck compression with the TRW system alone. All HIC<sub>36</sub><sup>20</sup> responses were extremely low and ranged from 8 to 90, with the maximum occurring in an open window test. Lateral shear and bending moment of the neck were also measured, although there are no established IARVs. The maximum lateral neck shear loads were 950 N (50th percentile male tested with TRW system) and 1020 N (5th percentile female tested with laminate only).

#### 2. Tests With 6-Year-Old Child Test Dummy Showed a Risk of Ejection Through Openings Not Fully Covered

The second research program involved a series of tests on the DRF using an unrestrained Hybrid III 6-year-old dummy. In previous tests with the 50th percentile adult male and 5th percentile adult female dummies, a gap formed between the inflatable devices and the window sill (bottom of the

window opening), which allowed partial ejection of those dummies. The second program investigated whether the gap allowed ejection of the 6-year-old child dummy.<sup>21</sup>

In baseline testing with an open side window without activation of an ejection mitigation countermeasure, the child dummy was fully ejected. In tests of the two inflatable systems tested in the first program (at the time of the second research program, the inflatable device formerly developed by Simula was then developed by Zodiac Automotive US (Zodiac)), the inflatable devices prevented full ejection of the 6-year-old child dummy in upright-seated positions (no booster seat was used). However, dummy loading on the systems produced gaps that did allow an arm and/or hand to pass through in some tests. Moreover, in a series of tests with the dummy lying in a prone position (the dummy was placed on its back at the height of the bottom of the window opening), representing a near worst-case ejection condition, the dummy was completely ejected at positions near the bottom of the inflatable devices (above the sill) with the TRW curtain, while the Zodiac system contained the dummy inside the test buck in all testing. Adding pre-broken advanced glazing with the TRW system managed to contain the dummy inside the test buck in all tests.<sup>22</sup>

#### 3. Differences in Design Between the Two Inflatable Systems

The two prototype inflatable devices tested had fundamentally different designs. The Zodiac/Simula prototype system used an inflatable tubular structure (ITS)<sup>23</sup> tethered near the base of the A and B-pillars that deployed a woven material over the window opening. (The Zodiac system differed from the originally-tested Simula design in that it had more window coverage. This was achieved by placing the ITS tether locations lower on the pillars and adding additional woven material.) The TRW prototype was more akin to a typical air bag curtain and was fixed to the A- and B-pillar at its end points and along the roof rail, but not tethered. The ITS differed from conventional air bags in that it was not vented. We believe that the better performance of the Zodiac prototype system compared to that of TRW, in the DRF testing described above and in impactor test

<sup>21</sup> "NHTSA's Crashworthiness Rollover Research Program," Summers, S., *et al.*, 19th International Technical Conference on the Enhanced Safety of Vehicles, paper number 05-0279, 2005.

<sup>22</sup> *Id.*

<sup>23</sup> ITS systems were originally introduced by BMW as a side impact countermeasure.

<sup>20</sup> HIC<sub>36</sub> is the Head Injury Criterion computed over a 36 msec duration. HIC<sub>36</sub> = 1000 represents an onset of concussion and brain injury.

results provided later in this preamble, was due to the greater window coverage by the Zodiac prototype along the entire sill and A-pillar.

#### 4. Insights

The DRF research provided the following insights into ejection mitigation curtains:

- Inflatable devices prevented ejection of test dummies in simulated rollover tests, but design differences accounted for differences in performance;
- Gaps in the inflatable device's coverage of the window opening at the sill and A-pillar allowed partial ejection of adult dummies and full ejection of a 6-year-old child dummy;
- Adding pre-broken advanced glazing to an air bag system enhanced the ability of the system to contain the dummy; and,
- To optimize ejection mitigation potential, a performance test should ensure that the countermeasure has full coverage of the window opening.

#### c. Comparable Performance in Simulated Rollovers and Component-Level Impact Tests

Because full-vehicle rollover crash tests can have an undesired amount of variability in vehicle and occupant kinematics, in the advanced glazing program NHTSA developed a component-level impact test for assessing excursion and the risk of ejection. The component-level test is basically the test proposed in this NPRM for ejection mitigation.<sup>24</sup> The test involves use of a guided linear impactor designed to replicate the loading of a 50th percentile male occupant's head and shoulder during ejection situations. The impactor<sup>25</sup> is described later in this preamble. There are many possible ways of delivering the impactor to the target location on the ejection mitigation countermeasure. The ejection mitigation test device<sup>26</sup> used in agency research has a propulsion mechanism<sup>27</sup> with a pneumatic piston that pushes the shaft component of the impactor. The shaft slides along a plastic (polyethylene)

bearing. The impactor has an 18 kg mass.

The component-level test identified four impact locations to evaluate a countermeasure's window coverage and retention capability. Two of the positions were located at the extreme corners of the window/frame and were located such that a 25 mm gap existed between the outermost perimeter of the headform and window frame. A third position was near the transition between the upper window frame edge and A-pillar edge. The fourth position was at the longitudinal midpoint between the third position and the position at the upper extreme corner of the window/door frame, such that the lowest edge of the headform was 25 mm above the surface of the door at the bottom of the window opening. At each impact location, different impact speeds and different time delays between air bag deployment and impact were used. To simulate ejection early in a rollover event and in a side impact, the air bags were impacted 1½ seconds after air bag deployment, at 20 and 24 km/h. To simulate ejection late in a rollover event, the air bags were impacted after a delay of 6 seconds at an impact speed of 16 km/h.

The two inflatable systems tested in the above-described research programs (the inflatable devices developed by Zodiac and by TRW) were installed on a Chevrolet CK pickup cab and subjected to the component-level impact test. The air bag systems were evaluated for allowable excursion (impactor displacement) beyond the side window plane. The tests also assessed the degree to which the component-level test was able to replicate the findings of the DRF tests.

The component-level tests mimicked the DRF tests by revealing the same deficiencies in the side curtain air bags that were highlighted in the dynamic test. The Zodiac system<sup>28</sup> did not allow the impactor to go beyond the plane of the window in the 16 km/h and 20 km/h tests. The air bag allowed only 12 and 19 mm of excursion beyond the window plane in the 24 km/h tests. In the 24 km/h tests of the TRW system, the curtain was not able to stop the impactor before the limits of travel were reached (about 180 mm beyond the plane for the vehicle window for that test setup) at the position at the extreme forward corner of the window sill. This is the position at which the TRW prototype system allowed excessive excursion of the test dummies in the

DRF dynamic tests. In the DRF tests, the 6-year-old dummy was completely ejected through that window area even when the prone dummy was aimed at the position at the other extreme corner of the window. In other tests, the TRW prototype system was able to stop the impactor before the impactor reached its physical stops.

#### d. Advantages of a Component Test Over a Full Vehicle Dynamic Test

The component test not only distinguishes between acceptable and unacceptable performance in side curtain air bags, but has advantages over a full vehicle dynamic test. The acceptable (or poor) performance in the laboratory test correlated to the acceptable (or poor) performance in the dynamic test. The component test was able to reveal deficiencies in window coverage of ejection mitigation curtains that resulted in partial or full ejections in dynamic conditions. NHTSA tentatively believes that incorporating the component test into an ejection mitigation standard would ensure that ejection mitigation countermeasures provide sufficient coverage of the window opening for as long in the crash event as the risk of ejection exists, which is a key component contributing to the efficacy of the system.

As noted earlier, rollover crash tests can have an undesirable amount of variability in vehicle and occupant kinematics. In contrast, the repeatability of the component test has been shown to be good.<sup>29</sup> Moreover, there are many types of rollover crashes, and within each crash type the vehicle speed and other parameters can vary widely. A curb trip can be a very fast event with a relatively high lateral acceleration. Soil and gravel trips have lower lateral accelerations than a curb trip and lower initial roll rates. Fall-over rollovers are the longest duration events, and it can be difficult to distinguish between rollover and non-rollover events. Viano and Parenteau<sup>30</sup> correlated eight different tests to six rollover definitions from NASS-CDS.<sup>31</sup> Their analysis indicated that the types of rollovers occurring in the real-world varied significantly. Soil trip rollovers accounted for more than 47 percent of the rollovers in the field, while less than 1 percent of real-world rollovers were

<sup>24</sup> "Technical Analysis in Support of a Notice of Proposed Rulemaking for Ejection Mitigation," *supra*.

<sup>25</sup> The "ejection impactor" is the moving mass that strikes the ejection mitigation countermeasure. It consists of an ejection headform attached to a shaft.

<sup>26</sup> The ejection mitigation test device consists of an ejection impactor and ejection propulsion mechanism.

<sup>27</sup> The "ejection propulsion mechanism" is the component that propels the ejection impactor and constrains it to move along its axis or shaft.

<sup>28</sup> Testing was restricted to the extreme corners of the window due to limited availability of this system.

<sup>29</sup> "NHTSA's Crashworthiness Rollover Research Program," *supra*.

<sup>30</sup> Viano D, Parenteau C. Rollover Crash Sensing and Safety Overview. SAE 2004-01-0342.

<sup>31</sup> "Technical Analysis in Support of a Notice of Proposed Rulemaking for Ejection Mitigation," *supra*.



represented by the FMVSS No. 208 dolly test.

Occupant kinematics will also vary with these crash types, resulting in different probabilities of occupant contact on certain areas of the side window opening with differing impact energies. A single full vehicle rollover test could narrowly focus on only certain types of rollover crashes occurring in the field.<sup>32</sup> NHTSA is concerned that a comprehensive assessment of ejection mitigation countermeasures through full vehicle dynamic testing may only be possible if it were to involve multiple crash scenarios. Such a suite of tests imposes test burdens that could be assuaged by a component test such as that proposed today. We also note that a comprehensive suite of full-vehicle dynamic tests would likely involve many more years of research, which would delay this rulemaking action and the potential for incorporating these life-saving technologies. Such a delay seems unwarranted since NHTSA believes the component test will be an effective means of determining the acceptability of ejection countermeasures. Whether it would be more or less effective than a yet-to-be-defined suite of full vehicle tests remains an open question. However, as explained above, the proposed test clearly has advantages over a single full vehicle test.

#### *e. Existing Curtains Can Be Made More Effective*

##### 1. Existing Curtains

The availability of vehicles that offer inflatable side curtains that deploy in a rollover has increased since they first became available in 2002. In the middle of the 2002 model year (MY), Ford introduced the first generation of side curtain air bags that were designed to deploy in the event of a rollover crash. The rollover air bag curtain system, marketed as a "Safety Canopy," was introduced as an option on the Explorer and Mercury Mountaineer.<sup>33</sup> For the 2007 MY, rollover sensors were available on approximately 95 models, with 75 of these models being sport utility vehicles. The system is standard equipment on 62 vehicles (65 percent)

<sup>32</sup> The agency has in the past performed dolly type dynamic testing. The agency has not performed enough repeat tests of the same vehicles to draw any conclusions about the repeatability of these tests to determine occupant containment. However, regardless of the level of repeatability of dummy kinematics, it still only represents a part of the kinematics that would occur in the field.

<sup>33</sup> [http://media.ford.com/article\\_display.cfm?article\\_id=6447](http://media.ford.com/article_display.cfm?article_id=6447).

and optional on 33 vehicles (35 percent).

In addition to the presence of a rollover sensor, there are two important design differences between air bag curtains designed for rollover ejection mitigation and air bag curtains designed for side impact protection. The first difference is longer inflation duration. Rollover crashes with multiple full vehicle rotations can last many seconds. Ford states that its Safety Canopy stays inflated for 6 seconds,<sup>34</sup> while GM has been reported to state that its side curtain air bags designed for rollover protection maintain 80 percent inflation pressure for 5 seconds.<sup>35</sup> Honda reportedly states that the side curtains on the 2005 and later Honda Odyssey stay fully inflated for 3 seconds.<sup>36</sup> (To our knowledge, Ford has not indicated what level of inflation is maintained during the duration.) In contrast, side impact air bag curtains designed for occupant protection in side crashes, generally stay inflated for less than 0.1 seconds.

The second important air bag curtain design difference between rollover and side impact protection is the size or coverage of the air bag curtain. One of the most obvious trends in newer vehicles is the increasing area of coverage for rollover curtains. Ford reportedly stated that its rollover protection air bags cover between 66 and 80 percent of the first two rows of windows, and that it was expanding the designs so they cover all three rows in all models.<sup>37</sup> GM reportedly stated that its curtains designed for rollover protection are larger than non-rollover curtains.<sup>38</sup>

##### 2. Component Tests of Real-World Curtains and Advanced Glazing Systems Show That Improvements Could Be Made

NHTSA has tested real-world side window air bag curtains and advanced glazing<sup>39</sup> according to the test procedure proposed in this NPRM, except for some differences in the target locations.<sup>40 41</sup> In addition, prototype

<sup>34</sup> *Ibid.*

<sup>35</sup> "Who Benefits From Side and Head Airbags?" (<http://www.edmunds.com/ownership/safety/articles/105563/article.html>).

<sup>36</sup> <http://www.autodeadline.com/detail?source=Honda&mid=HON2004083172678&mime=ASC>.

<sup>37</sup> *Ibid.*

<sup>38</sup> "Who Benefits From Side and Head Airbags?" (<http://www.edmunds.com/ownership/safety/articles/105563/article.html>).

<sup>39</sup> The laminates tested were marketed as theft protection and not as a form of ejection mitigation.

<sup>40</sup> "Status of NHTSA's Ejection Mitigation Research Program," *supra*.

<sup>41</sup> "NHTSA Crashworthiness Rollover Research Program," *supra*.

Zodiac and TRW systems were installed on the GM CK pickup and the Lincoln Navigator. In this section of the preamble, we provide test results for ejection mitigation countermeasures installed as original equipment (OE) and as prototypes, tested to the proposed requirements. One of the findings of this test series was that none of the original equipment (OE) systems met the proposed displacement limit when impacted at the target in the forward lower corner of the front window (target A1, see Figure 1 below) at 24 km/h.<sup>42</sup>

The target locations shown in Figure 1 were determined by the method proposed for this NPRM. With the exception of the Honda Odyssey, for all tests of prototype systems and OE system through MY05, the method for determining the target location was slightly different than currently proposed. (We will refer to this method as the "research target method" as opposed to the "proposed target method.") The MY05 Odyssey was tested by the proposed target method. As explained below, the differences in target locations identified by the two methods are small enough that data using the research target method can be reasonably compared to the proposed target method.

The difference in determining the target location had the most effect on the location of A2, A3, B1 and B4. The resulting shift in target location was a function of the window shape. The primary difference in the research target method was that A3 was found by bisecting the angle produced by the intersection of a line parallel to the A-pillar and roof rail, which in the case of the window in Figure 1 would shift A3 rearward and upward. Since A2 is located horizontally midway between A3 and A4 in both the research and proposed target methods, A2 in the research target method would be rearward of the A2 position shown in Figure 1.

The rear window data for prototype and OE system through MY05 is, for the most part, limited to B1 and B4. Under the research target method used to find the target locations, B1 was at the lower sill, in the middle of the window and B4 was in the upper rear corner. Again, under the research target method, B1 and B4 would likely be shifted forward from the location shown in Figure 1. For the test of the Zodiac prototype on the Navigator, extra targets were impacted. For only this vehicle, Tables 1 through 3 of this preamble present an average

<sup>42</sup> "Technical Analysis in Support of a Notice of Proposed Rulemaking for Ejection Mitigation," *supra*.



result from two impacts that were on either side of the proposed targets B1 and B4.

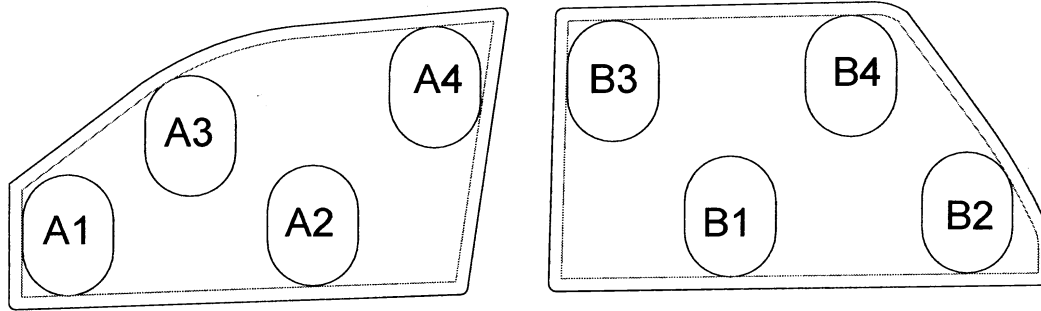

Figure 1 – Target Location Determined by Proposed Method

The results of the testing are given in Tables 1 through 3. The results are given in columns, by target location. These data are also found in a color coded format in the Technical Analysis report accompanying this NPRM. The target location key is shown in Figure 1 of this preamble, supra. In general, for a particular vehicle and target location, if multiple trials were run at a particular impact speed and time delay, each of the displacement results is shown by separating the table cell into two or three cells.

Although the agency is proposing a 24 km/h impact test 1.5 seconds after air bag deployment, research data was acquired at 20 km/h to determine the sensitivity to impact speed. Several ejection mitigation systems were not tested at 24 km/h at every target location

because the 20 km/h results indicated displacements in excess of 100 mm at that location. We assume the 24 km/h impact would also have exceeded 100 mm. Where this occurred, the cell in Table 1 contains the 20 km/h displacement value and is identified by an asterisk. Similarly, some target locations were not tested at 20 km/h, but we assume that the value that would have been obtained would be below 80 mm of displacement because the 24 km/h impact was less than 80 mm. Where this occurred, the cell in Table 2 contains the 24 km/h displacement value and is identified by a double asterisk.

Tables 1 through 3 show the results for vehicle front windows. For all three sets of tests, A1 was the most challenging target and A4 was the least

challenging. For the 24 km/h test, the only system that did not exceed the 100 mm criterion at A1 was the Zodiac prototype on the CK pickup. At 20 km/h, the MY05 Infinity had one test result of 99 mm and another of 106 mm at A1. For the 16 km/h impact at a 1.5 second delay, two OE systems and two prototype systems had displacements slightly more or less than 100 mm at A1. No displacement at A4 exceeded 76, 73 or 67 mm at 24, 20 and 16 km/h, respectively. Taken as a whole, A2 and A3 showed similar results to each other for all three test conditions in that neither was as consistently challenging to meet as A1 nor as easily met as A4. The trends for severity by target location are the same for the 16 km/h impacts at a 6 second delay.

TABLE 1—IMPACTOR DISPLACEMENT—FRONT ROW WINDOW, 24 KM/H IMPACT, 1.5 SECOND DELAY

	Position A1	Position A2	Position A3	Position A4
03 Navigator	No Data	* 186 196*	* 229	- 22.
03 Navigator w/lam	No Data	35	No Data	No Data.
04 Volvo XC90	* 163	193	130	18.
04 Volvo w/lam	* 102 * 151	44	118	15.
05 Nissan Pathfinder	* 181	161	* 240	76 76.
05 Toyota Highlander	* 159 * 164	202	137	67.
05 Infinity FX35	124	83 96 112	89 89 108	53.
05 Chevy Trailblazer	138	168	159	No Data.
05 Chevy Trailblazer w/lam	No Data	No Data	* 107 * 110	No Data.
05 Honda Odyssey	No Cover	119	107	No Data.
06 Dodge Durango	174	156	* 180	54.
06 Dodge Durango w/lam	No Data	* 101	No Data	No Data.
Zodiac Prot. on CK	12	19	No Data	No Data.
Zodiac Prot. on Navigator	150 143	54	96 102	21 24.
Zodiac Prot. on Nav. w/lam	No Data	No Data	91 97	No Data.
TRW Prot. on CK	No Cover†	82 82 102	2 6	- 13 - 8.
TRW Prot. on CK w/lam	180 182	21	- 26 - 26	- 33 - 25.

\* Only tested at 20 km/h and displacement exceeded 100 mm.

† No countermeasure at this target location.

TABLE 2—IMPACTOR DISPLACEMENT—FRONT ROW WINDOW, 20 KM/H IMPACT, 1.5 SECOND DELAY

	Position A1	Position A2	Position A3	Position A4
03 Navigator	No Data	186 196	229	-37.
03 Navigator w/theft lam	No Data	6	No Data	No Data.
04 Volvo XC90	163	84 107	107 131	-3.
04 Volvo w/theft lam	102 151	27	97	** 15.
05 Nissan Pathfinder	181	133	240	58
05 Toyota Highlander	159 164	113 150	106 113	73.
05 Infinity FX35	99 106	58	70	29.
05 Chevy Trailblazer	112	121	127	No Data.
05 Chevy Trailblazer w/lam	90	80	109	No Data.
05 Honda Odyssey	No Cover †	96	57	-45.
06 Dodge Durango	160	140	180	18.
06 Dodge Durango w/lam	No Data	101	No Data	No Data.
Zodiac Prot. on CK	-12	-9	No Data	No Data.
Zodiac Prot. on Navigator	122	38	76 81	-9 -0.9.
Zodiac Prot. on Nav. w/lam	No Data	No Data	No Data	No Data.
TRW Prot. on CK	No Cover †	75	-29	-52.
TRW Prot. on CK w/lam	104	0	-54	-60 -63.

\*\* Only tested at 24 km/h and displacement was below 80 mm.

† No countermeasure at this target location.

TABLE 3—IMPACTOR DISPLACEMENT—FRONT ROW WINDOW, 16 KM/H IMPACT, 6 SECOND DELAY

	Position A1	Position A2	Position A3	Position A4
03 Navigator	243	74	211	-30.
03 Navigator w/theft lam	157	-14	137	No Data.
04 Volvo XC90	154 167	52 93	78	-22.
04 Volvo w/theft lam	86 105	26	59	No Data.
05 Nissan Pathfinder	108 120	93 106	188	37 46.
05 Toyota Highlander	198	132	147	67.
05 Infinity FX35	85	21	39	9.
05 Chevy Trailblazer	121	192	124	No Data.
05 Chevy Trailblazer w/lam	No Data	102	No Data	No Data.
05 Honda Odyssey	No Cover †	77	47 90	-54.
06 Dodge Durango	138	135	167	13.
06 Dodge Durango w/lam	No Data	No Data	142	No Data.
Zodiac Prot. on CK	0	0	No Data	No Data.
Zodiac Prot. on Navigator	135	49	78 81	-0.2.
Zodiac Prot. on Nav. w/lam	104	No Data	70	No Data.
TRW Prot. on CK	No Cover †	99 97	-36	-41.
TRW Prot. On CK w/lam	80	-3	-44	-67.

† No countermeasure at this target location.

The 2nd row window data in Tables 4 through 6 are much more limited, with nearly all the data at B1 and B4. In general, these data indicate target location B1 is more challenging than B4. The exception to this is the Dodge Durango, which performed well at all 2nd row targets. For the 24 km/h test at B1, three of the ejection mitigation systems tested had displacements that did not exceed 100 mm. For the 20 and 16 km/h test at B1, a total of 3 systems

did not exceed 100 mm. We also expect that the Durango would not have exceeded 100 mm at 20 km/h, since it did not exceed 100 mm at 24 km/h. At B4, three systems had displacements that exceeded 100 mm. This was reduced to one system for the 20 and 16 km/h impacts.

Any cell listed as “To Stops” indicates a displacement of the impactor to the point where the mechanical stops of the device keep it from further

movement. This occurred for the MY03 Navigator at B1 at 24 and 20 km/h. “To stops” is considered an infinite displacement and indicates very little countermeasure coverage at this location.

Table 7 shows very limited 3rd row window data for the Odyssey and Durango at all test conditions. For this system C4 is much more challenging than C1.<sup>43</sup>

TABLE 4—SECOND ROW WINDOW, 24 KM/H IMPACT, 1.5 SECOND DELAY

	Position B1	Position B2	Position B3	Position B4
03 Navigator	To Stops	No Data	No Data	-40.
04 Volvo XC90	(20 km/h) *	No Data	No Data	69.
04 Volvo w/theft lam	91/93	No Data	No Data	62.
05 Nissan Pathfinder	161	No Data	No Data	128.

<sup>43</sup> We are using C1 through C4 to denote the impact locations for the 3rd row window. Third

row target locations were found in the same manner as 2nd row targets.

TABLE 4—SECOND ROW WINDOW, 24 KM/H IMPACT, 1.5 SECOND DELAY—Continued

	Position B1	Position B2	Position B3	Position B4
05 Toyota Highlander .....	146 .....	No Data .....	No Data .....	149.
05 Infinity FX35 .....	143 .....	No Data .....	No Data .....	45.
05 Honda Odyssey .....	71 .....	152 .....	80 .....	193.
06 Dodge Durango .....	76 .....	86 .....	91 .....	82.
Zodiac Prot. on Navigator .....	Avg. = 98 (96 to 100)‡.	99 .....	No Data .....	Avg. = 104 (32 to 176)‡.

\* Exceeded 100 mm at 20 km/h.

‡ Combines data from two impact location closest to the defined target location.

TABLE 5—SECOND ROW WINDOW, 20 KM/H IMPACT, 1.5 SECOND DELAY

	Position B1	Position B2	Position B3	Position B4
03 Navigator .....	To Stops .....	No Data .....	No Data .....	- 14.
04 Volvo XC90 .....	183 .....	No Data .....	No Data .....	(24 km/h)**.
04 Volvo w/theft lam .....	94 .....	No Data .....	No Data .....	(24 km/h)**.
05 Nissan Pathfinder .....	126/150 .....	No Data .....	No Data .....	99.
05 Toyota Highlander .....	107 .....	No Data .....	No Data .....	102.
05 Infinity FX35 .....	79 94 .....	No Data .....	No Data .....	21.
05 Honda Odyssey .....	42 .....	134 .....	34 .....	84.
06 Dodge Durango .....	(24 km/h) .....	No Data .....	No Data .....	No Data.
Zodiac Prot. on Navigator .....	Avg. = 70 (67 to 72)‡.	70 .....	No Data .....	Avg. = 77 (9 to 144)‡.

‡ Combines data from two impact location closest to the defined target location.

\*\* Below 80 mm at 24 km/h.

TABLE 6—SECOND ROW WINDOW, 16 KM/H IMPACT, 6 SECOND DELAY

	Position B1	Position B2	Position B3	Position B4
03 Navigator .....	126 .....	No Data .....	No Data .....	- 27.
04 Volvo XC90 .....	189 .....	No Data .....	No Data .....	29.
04 Volvo w/theft lam .....	63 .....	No Data .....	No Data .....	9.
05 Nissan Pathfinder .....	104 .....	No Data .....	No Data .....	75.
05 Toyota Highlander .....	138 .....	No Data .....	No Data .....	107.
05 Infinity FX35 .....	61 .....	No Data .....	No Data .....	19.
05 Honda Odyssey .....	12 .....	121 .....	55 .....	28.
06 Dodge Durango .....	3 .....	36 .....	71 .....	18.
Zodiac Prot. on Navigator .....	Avg. = 81 (73 to 89) †.	98 .....	No Data .....	Avg. = 67 (16 to 117) †.

† Combines data from two impact location closest to the defined target location.

TABLE 7—THIRD ROW WINDOW, ALL IMPACT SPEEDS AND TIME DELAYS

	Position C1	Position C2	Position C3	Position C4
24 km/h—1.5 s				
05 Honda Odyssey .....	No Data .....	No Data .....	175 .....	(20 km/h)*.
06 Dodge Durango .....	No Data .....	No Data .....	No Data .....	(20 km/h)*.
20 km/h—1.5 s				
05 Honda Odyssey .....	58 .....	No Data .....	122 .....	To Stops.
06 Dodge Durango .....	66 .....	No Data .....	No Data .....	283.
16 km/h—6 s				
05 Honda Odyssey .....	44 .....	To Stops .....	80 .....	331.
06 Dodge Durango .....	52 .....	No Data .....	No Data .....	No Data.

\* Exceeded 100 mm at 20 km/h.

Summarized below are some very general trends for the displacement data. These trends were based on limited data and were not analyzed for statistical significance.

Within target locations we found the following general trends:

- The 24 km/h—1.5 second delay test was the most challenging test;

- The 20 km/h—1.5 second test was more consistently challenging than the 16 km/h—6 second test;

- For the 24 km/h test, the only system that did not exceed the 100 mm criterion at A1 was the Zodiac Prototype on the CK pickup.

Comparing target locations we found the following general trends:

- In row one, A1 was the most consistently challenging target and A4 was the least;

- In row two, target location B1 was more consistently challenging than target B4;

- Data from the third row targets were too limited to indicate any trends.

3. Use of advanced glazing with the air bag curtain resulted in reduced displacement

Several vehicles were tested both with and without laminated glazing. A prototype glazing was used on the CK pickup. Tests where advanced glazing was used resulted in a reduction in impactor displacement. Table 8 shows the reduction in impactor displacement for each of the vehicles. Not every target location was tested at each impact

speed. For all prototype and MY06 and older vehicles, the glazing was pre-broken using a ball-peen hammer method discussed in the Technical Analysis report accompanying this NPRM, while for MY07 vehicles, the glazing was broken using a 50 mm matrix hole punch pattern. (The agency is proposing the latter method in this NPRM.)

The largest displacement reduction was for the MY03 Navigator at A2, impacted at 20 km/h—1.5 second delay.

This location exhibited a 185 mm change in displacement (from 191 mm to 6 mm). The smallest change in displacement was 3 mm (18 mm to 15 mm) for the MY04 XC90 at A4, impacted at 24 km/h—1.5 second delay. For target positions with multiple vehicle tests, the A2 position had the largest change in displacement at each test speed. The average displacement reduction across target locations and test types was 51 mm.

TABLE 8—REDUCTION IN IMPACTOR DISPLACEMENT RESULTING FROM PRE-BROKEN LAMINATED GLAZING

	A1	A2	A3	A4	B1	B4
24 km/h, 1.5 sec.:						
04 Volvo XC90 .....		149	12	3		7
Zodiac Prot. on Navigator .....			5			
TRW Prot. on CK .....		68	30	19		
Average .....		108	16	11		
20 km/h, 1.5 sec.:						
03 Navigator .....		185				
04 Volvo XC90 .....	37	69	22		89	
05 Trailblazer .....	22	41	19			
06 Durango .....		47				
TRW Prot. on CK .....		75	25	10		
Average .....	29	83	22			
16 km/h, 6 sec.:						
03 Navigator .....	86	88	74			
04 Volvo XC90 .....	65	47	19		126	20
05 Trailblazer .....		90				
06 Durango .....			25			
07 Commander .....		91				
Zodiac Prot. on Navigator .....	31		10			
TRW Prot. on CK .....		101	8	26		
Average .....	61	83	27			

4. Field Performance of Ejection Mitigation Curtain Systems

To better understand the field performance of the current fleet equipped with rollover systems, the agency evaluated available crash data. A focus of this evaluation was the performance of the rollover sensors and their ability to detect the rollover event and activate deployment of the side curtain air bags. We also sought to understand the occupant containment provided by the vehicle system. The available data reviewed included a detailed analysis of a very limited number of rollover crashes by NHTSA's Special Crash Investigation (SCI) division. In all of the cases, the ejection

countermeasure in the vehicle was an air bag curtain which partially covered the first two window rows.

The agency's SCI division analyzed seven real-world rollover crashes of Ford vehicles where the subject vehicles contained a rollover sensor and side curtain air bags. (Ford agreed to notify SCI of the crashes.) The subject vehicles were Ford Expeditions, a Ford Explorer, a Mercury Mountaineer, and a Volvo XC90. Table 9 gives details about each case.

In each case, the rollover sensor deployed the side curtain air bag. Of the seven cases, there were a total of 19 occupants, 15 of whom were properly restrained. All were in lap/shoulder belts, except one child in a rear facing

child restraint system (CRS). A single crash (DS04-016) had all of the unrestrained occupants, serious injuries, fatalities and ejections in this set of cases. Two of the four unrestrained occupants were fully ejected from the vehicle, resulting in one fatal and one serious injury. The fatality was a 4-month-old infant, seated in the middle of the 2nd row. The ejection route was not determined. The seriously injured occupant was an adult in the left 3rd row, ejected through the uncovered right side 3rd row window. One non-ejected, restrained occupant received a fatal cervical fracture resulting from roof contact and another was seriously injured. The injuries to the remaining occupants were "none" to "minor."

TABLE 9—FORD SCI ROLLOVER CASES

Case	Make	Model	MY	Occupants			1/4 Rot.	Deploy		
				Row 1	Row 2	Row 3		Angle	Time (ms)	Rate (deg/s)
CA02-059 .....	Mercury ....	Mount .....	2002	1R .....	1R .....	.....	1	17 .....	.....	17 to 25.
CA04-010 .....	Ford .....	Expl .....	2003	1R .....	.....	.....	1	43 .....	20 .....	75.
IN-02-010 .....	Ford .....	Exped .....	2003	1R .....	.....	.....	2	45 .....	146 .....	111.
2004-003-04009 ....	Ford .....	Exped .....	2003	1R .....	2R .....	.....	5	Yes .....	Unknown	Unknown.

TABLE 9—FORD SCI ROLLOVER CASES—Continued

Case	Make	Model	MY	Occupants			¼ Rot.	Deploy		
				Row 1	Row 2	Row 3		Angle	Time (ms)	Rate (deg/s)
DS04-016 .....	Ford .....	Exped .....	2003	2R .....	2R, 2NR †	1R, 2NR †	5	Yes .....	Unknown	Unknown.
DS04017 .....	Ford .....	Exped .....	2004	1R .....	.....	.....	12	Yes .....	Unknown	Unknown.
2003-079-057 .....	Volvo .....	XC90 .....	2003	1R .....	1R .....	.....	6	Yes .....	Unknown	Unknown.

R = Restrained, NR = Not Restrained.

† One NR 2nd and 3rd row occupant ejected (total of 2 ejected).

**V. Proposed Ejection Mitigation Requirements and Test Procedures**

As discussed above, NHTSA’s research on rollover ejection found that with partial window opening coverage by a curtain, occupants initially contacting covered areas can slide to an opening and be ejected. The agency is proposing a test that requires ejection mitigation curtains to retain an impactor such that its displacement is limited to a specified distance outside of the window. To assure full window opening coverage through the duration of a rollover, the proposed test procedure would require the first three rows of side window openings to be impacted at up to four locations around the perimeter of the opening at two time intervals.

In this section, we discuss in detail the rationale for selection of the

impactor test parameters. The primary parameters that determine the stringency of the test are: (a) The impactor dimensions and mass; (b) the displacement limit; (c) impactor speed and time of impact; and (d) target locations. We also discuss: (e) glazing issues; (f) test procedure tolerances; (g) test device characteristics; and (h) a proposal for a telltale requirement. See also “Technical Analysis in Support of a Notice of Proposed Rulemaking for Ejection Mitigation,” supra.

*a. Impactor Dimensions and Mass*

The component test involves use of a guided linear impactor designed to replicate the loading of a 50th percentile male occupant’s head and upper torso during ejection situations. The portion of the impactor that strikes the countermeasure is a featureless headform that was originally designed

for the upper interior head protection research program (FMVSS No. 201).<sup>44</sup> It averages the dimensional and inertial characteristics of the frontal and lateral regions of the head into a single headform. The headform is covered with an approximately 10 mm thick dummy skin material whose outer surface dimensions are given in Figure 2, below. The Technical Analysis report discusses other dimensional attributes of the headform, such as the curvature of the outer surface. There are many possible ways of delivering the impactor to the target location on the ejection mitigation countermeasure. The impactor used in agency research propels the shaft component of the impactor with a pneumatic piston. The shaft slides along a plastic (polyethylene) bearing. The impactor has an 18 kg mass.<sup>45</sup>

<sup>44</sup> “Ejection Mitigation Using Advanced Glazings: A Status Report,” November 1995, Docket NHTSA-1996-1782-3; “Ejection Mitigation Using Advanced Glazings: Status Report II,” August 1999, Docket NHTSA-1996-1782-21; “Ejection Mitigation Using

Advanced Glazings: Final Report,” August 2001, Docket NHTSA-1996-1782-22.

<sup>45</sup> Since the proposed performance criterion for this ejection mitigation standard is a linear displacement measure (a linear displacement measure would correlate to the actual gap through

which an occupant can be ejected), a linear impactor appears to be a suitable tool to dynamically measure displacement. The impactor can be placed inside the vehicle for testing the ejection mitigation curtains and glazing covering window openings.

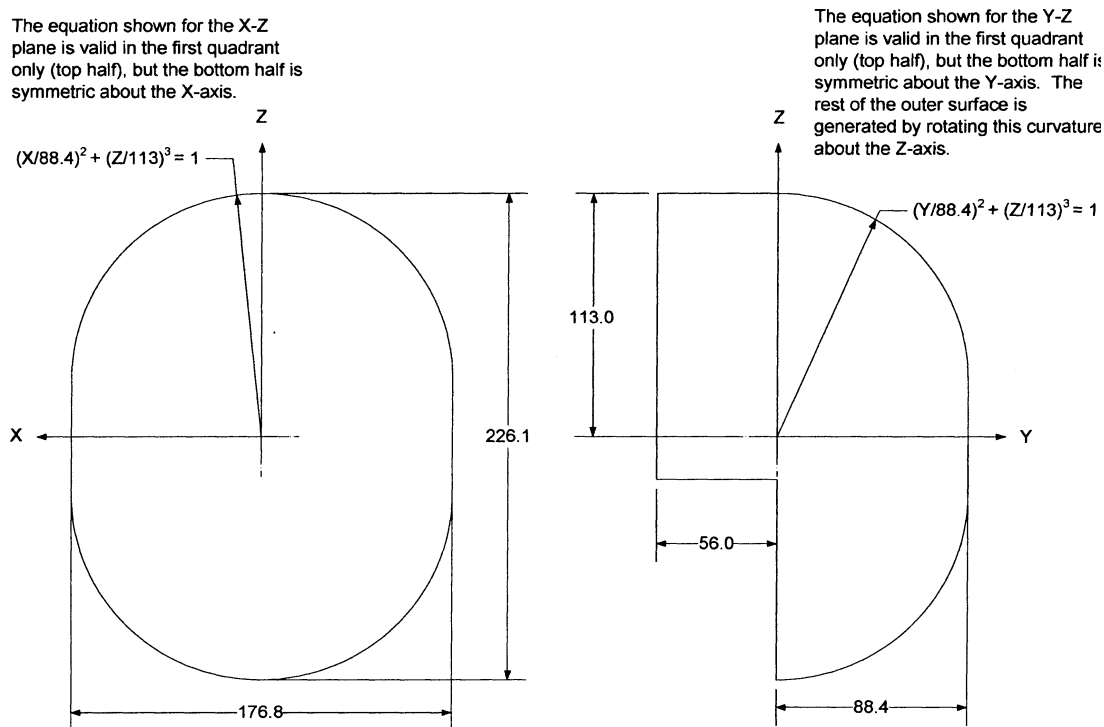

**Figure 2 – Front and side view of headform outer surface (right) with dimensions given in millimeters**

The mass of the guided impactor was developed through pendulum tests, side impact sled tests, and modeling conducted to determine the mass imposed on the window opening by a 50th percentile adult male's upper torso and head during an occupant ejection ("effective mass").<sup>46</sup> Briefly, the pendulum impact tests were conducted on a BioSID anthropomorphic test device (50th percentile adult male) to measure effective mass of the head, shoulder, and upper torso. The BioSID was chosen because it was originally configured for side impact, unlike the Hybrid III dummy, and has a shoulder which the Side Impact Dummy (49 CFR 572, subpart F) currently used for FMVSS No. 214, "Side impact protection," does not have. A linear impact pendulum weighing 23.4 kg (51.5 lb) was used to strike the head and shoulder of the dummy laterally (perpendicular to the midsagittal plane) using two impact speeds (9.7 and 12.9 km/h) and four impact surfaces. In addition to the rigid impactor face, three types of padding were added to the impactor face to increase the contact time, to replicate advanced glazing impacts.

Effective mass was calculated by dividing the force time history calculated from the pendulum accelerometers by the acceleration time history from the dummy sensors. In general, higher speed impacts and impacts with softer surfaces generated higher effective mass. Based on these pendulum tests, a range for the effective mass of the head and upper torso was estimated to be 16 to 27 kg.

In the sled tests, we used a side impact sled buck with a load plate representing a door and two load plates representing the glazing to measure shoulder and head impacts with three different stiffness foams. The purpose of these tests was to determine the effect lower body loading would have on the combined head and upper torso effective mass. Two impact conditions were simulated, one representative of a rollover event and the second of a side impact event.

In the rollover condition, the impact speed was 16.1 km/h and the dummy was positioned leaning towards the door such that the head and torso would contact the simulated glazing at the same time. This leaning position was intended to be more representative of an occupant's attitude in a rollover. For the test designed to be more representative of a side impact condition, the dummy was seated upright and the impact

speed was 24 km/h. The effective mass of the head and upper torso calculated for the 16.1 km/h impact condition showed a quick rise to about 18 kg by about 5 ms, followed by an increase to about 40 kg at about 30 ms. The effective mass for the 24 km/h impact condition showed an initial artificially high value or spike prior to 5 ms because of a lag between the force measured in the load plates and the acceleration measured at the upper spine. This spike was also seen in the some pendulum shoulder impacts. The effective mass settled to about 9 kg at about 10 ms, with a slow rise to about 18 to 20 kg at about 25 to 30 ms. Looking at the results, we determined that early in each event, when the impacting mass is traveling near the pre-impact velocity, the energy levels of a 9 kg mass traveling at 24 km/h [ $9 \text{ kg} \times (6.67 \text{ m/s})^2/2 = 200 \text{ Nm}$ ] and an 18 kg mass traveling at 16 km/h [ $18 \text{ kg} \times (4.47 \text{ m/s})^2/2 = 180 \text{ Nm}$ ] were roughly the same. In consideration of the similarity of energy results for the sled testing at two impact speeds, we deferred to the 18 kg effective mass since the test condition more closely represented a rollover. In addition, the 18 kg value was within the range of the pendulum impactor results discussed above, which showed an effective mass range between 16 and 27 kg.

<sup>46</sup> "Technical Analysis in Support of a Notice of Proposed Rulemaking for Ejection Mitigation," supra.

The final part of the analysis involved computer modeling of an 18 kg impactor and 50th percentile Hybrid III dummy impacting simulated glazing (foam). The comparison found that the total energy transferred by the 18 kg impactor was within the range of the total energy transferred by the entire dummy. For a 16.1 km/h dummy model impact with the foam, the effective mass that came in contact with the foam was between 12.5 kg and 27 kg.

We note that the 18 kg proposed mass is consistent with that used by General Motors (GM) in 16.2 km/h (4.5 m/s) tests of ejection mitigation curtains.<sup>47</sup> GM based this value on test results from 52 full vehicle rollover tests that estimated the effective mass of occupant contact with the first row side window area. Forty-six percent of the tests were less than a ¼-turn, 27 percent were one ¼-turn and 27 percent were two ¼-turns. (Twenty of the rollovers were curb trip; 18 were soil trip; 11 were fall-over, and 3 were corkscrew.) The tests used two 50th percentile male Hybrid III dummies in the front seats. In half of the tests, the dummies were belted and in half they were not. A membrane was placed over the window area to prevent ejections, and tri-axial load cells were incorporated into the membrane at the corners of the window opening. The effective mass was calculated using the resultant loading on the dummy head by the window membrane, along with resultant head and chest accelerations.

For a subset of tests the effective mass was calculated using the impulse and momentum principle represented by:

$$\int F dt = m \Delta v$$

Where:

F = membrane contact force

m = effective mass

$\Delta v$  = change in occupant velocity

Results were similar for tests employing both methods. The estimated effective mass for most belted tests was about 5 kg and all were less than 10 kg. The majority of belted tests had effective masses which were a combination of both the near and far side occupants. The effective mass for the unbelted occupants ranged from 5 to 85 kg. However, we note there was a 40 kg effective mass for a single unbelted occupant contact. Energy levels calculated by using effective mass and peak head velocity were all below 182.25 Nm. This is the amount of energy imparted in GM's internal impactor testing (18 kg impactor and a 16.2 km/h (4.5 m/s) velocity).

### Request for Comments on the Impactor

In summary, the impactor mass was based on the determination of an effective mass calculated through both pendulum and sled test impacts. Sled tests designed to represent both side impacts and rollover impacts gave similar energies and two equivalent mass estimates. The 18 kg equivalent mass was seen during the test intended to be more representative of a rollover event. This was also the equivalent mass calculated from pendulum impact into the dummy shoulder. Thus, the 18 kg equivalent mass is considered a reasonable representation of an occupant's head and a portion of the torso. An equivalent mass more representative of just the head would be substantially smaller and an equivalent mass accounting for more torso and lower body mass would be substantially more. The 18 kg mass is well within the effective mass GM estimates from vehicle rollover tests, and is consistent with the impactor that GM uses to evaluate side curtains. Comments are requested on the 18 kg mass for the linear impactor headform.

#### b. Displacement Limit (100 mm)

We are proposing that the linear travel of the impactor headform must be limited to 100 mm from the inside of the tested vehicle's glazing as measured with the glazing in an unbroken state. The 100 mm boundary would be first determined with the original glazing "in position" (up) and unbroken. Then, for the test, the original glazing would be either: (a) In position but pre-broken; or (b) removed altogether, at the manufacturer's option.

The window-breaking procedure will damage but not destroy advanced (laminated) glazing, while it will obliterate tempered glazing. For vehicles with advanced glazing, the damaged glazing would be permitted to be in position under option (a), above. Tempered glazing will disintegrate when subjected to the window-breaking procedure, so under option (b), above, manufacturers may remove or completely retract the window since it would be destroyed in the pre-breaking procedure and would have no effect on the ejection mitigation results. When tested with the original glazing in position but pre-broken or with the glazing removed, the linear travel of the impactor headform must not exceed the 100 mm limit. If a side curtain air bag is present, and we anticipate that most, if not all, vehicles will have an ejection mitigation curtain, the curtain would be

In the test, the ejection mitigation countermeasure must prevent the headform from exceeding the 100 mm limit. The principle underlying the 100 mm displacement limit is to ensure that the countermeasure (curtain) does not allow gaps or openings to form through which occupants can be ejected. In the component test results, targets that had displacements of less than 100 mm did not eject the dummy in dynamic testing. As discussed previously in this preamble, the TRW and Zodiac prototype ejection mitigation countermeasures were tested on a CK pickup to the proposed impactor test procedure.<sup>48</sup> The TRW prototype had no coverage at position A1 (front window forward lower position), so the displacement in the impactor test was unlimited for all impact speeds and time delays (displacements well over 100 mm at position A1). These systems were later tested on the DRF with the 50th percentile male, 5th percentile female and 6-year-old dummies in upright seating positions, and a prone 6-year-old dummy aimed at approximately the target positions A1 and A2 (front window rear lower position). When tested on the DRF, the arms of the upright dummies flailed out of the window opening up to the shoulder at the sill (A1 and A2) and the prone 6-year-old dummy was completely ejected at A1.

It is noted, however, that dummy ejection did not occur all the time at targets that had displacements of over 100 mm. When tested with pre-broken laminated glazing, at position A1 the TRW system had a 181 mm of displacement at the 24 km/h (1.5 second delay) test and 104 mm of displacement in the 20 km/h (1.5 second delay) test, but did not eject either the prone or seated dummies in DRF tests. Nonetheless, the component and DRF testing indicate that there is an increased likelihood that a gap could be formed between the curtain and the window opening through which an occupant could be ejected if the displacement were over 100 mm in the headform test. In addition, a 100-mm limit would also help guard against the countermeasure being overly pliable or elastic so as to allow excessive excursion of an occupant's head and shoulders outside of the confines of the vehicle even in the absence of a gap.

A 100-mm performance limit is used in several regulations relating to occupant retention. In FMVSS No. 217, "Bus emergency exits and window retention and release" (49 CFR 571.217),

<sup>48</sup> There were only some slight variations in target locations.

<sup>47</sup> O'Brian-Mitchell, Bridget M., Lange, Robert C., "Ejection Mitigation in Rollover Events—Component Test Development," SAE 2007-01-0374.



bus manufacturers are required to ensure that each piece of glazing and each piece of window frame be retained by its surrounding structure in a manner that prevents the formation of any opening large enough to admit the passage of a 100-mm diameter sphere under a specified force. The purpose of the requirement is to minimize the likelihood of occupants being thrown from the vehicle. This value is also used in FMVSS No. 206, "Door locks and door retention components" (49 CFR 571.206; as amended 69 FR 75020). In FMVSS No. 206, the door is loaded with 18,000 N and the space between the interior of the door and the exterior of the door frame must be less than 100 mm. In addition, NHTSA also considered that a value of approximately 100 mm is used by the International Code Council (ICC) in developing building codes used to construct residential and commercial buildings.<sup>49</sup> The ICC 2006 International Building Code and 2006 International Residential Code require guards to be placed around areas such as open-sided walking areas, stairs, ramps, balconies and landings. The guards must not allow passage of a sphere 4 inches (102 mm) in diameter up to a height of 34 inches (864 mm). The ICC explains in the Commentary accompanying the Codes that the 4-inch spacing was chosen after considering information showing that the 4-inch opening will prevent nearly all children 1 year in age or older from falling through the guard.

#### Request for Comments on the Displacement Limit

NHTSA requests comment on the linear displacement limit of 100 mm as an appropriate value. We note that GM developed a test procedure that also uses a 100 mm displacement limit,<sup>50</sup> but the zero displacement plane is defined in a slightly different way. GM places a plane tangent to the exterior of the side of the vehicle at the target location and defines the displacement perpendicular to this excursion plane. Thus, the allowable GM displacement would be

approximately  $100/\cos(\theta)$  mm if other aspects of the test were identical to those of today's NPRM, with  $\theta$  being the angle with the vertical of the exterior plane. If  $\theta$  were 20 degrees, the GM limit would be approximately 106 mm, which allows slightly more displacement than the 100 mm proposal. The GM method also results in a slightly different allowable final displacement position than the proposed method because of the separation between the flat excursion plane and the inside surface of the window at the target location.<sup>51</sup> We do not know how that difference affects the final allowable displacement of the headform.

The agency further notes that an advantage to the displacement limit is that the linear displacement of the headform can be measured in a practicable and relatively straightforward manner, unlike a real-time dynamic measurement of a gap during an impact. The latter would likely involve complex and multiple imaging systems. Comments are requested on this issue.

#### c. Speed(s) and Time(s) at Which the Headform Would Impact the Countermeasure

As will be discussed in this section, there appears to be a need for a relatively high speed impact shortly after countermeasure deployment and a lower speed impact late in the deployment. The two time delays correspond to relatively early and late times in a rollover event.<sup>52</sup> The first impact would be at 24 km/h, and at 1.5 seconds after countermeasure deployment (1.5 second time delay). The second impact would be a 16 km/h impact initiated 6 seconds after deployment.

We are proposing and requesting comments on two alternatives regarding the testing of the four target locations for each window opening (see subsection 4, below). Only one of the alternatives would be selected for the final rule. The first proposal would subject all four target locations to both the 16 km/h (6 second time delay) and the 24 km/h (1.5 second time delay) impacts (which would amount to eight impacts per

window). The second proposal would be to apply the 16 km/h (6 second time delay) test on all four target locations but just apply the 24 km/h (1.5 second time delay) test to the location that had the greatest displacement in the 16 km/h (6 second time delay) test (which would amount to five impacts per window). The second approach would reduce the costs and burdens of the impact tests per vehicle.

#### 1. Ejections Can Occur Both Early and Late in the Rollover Event

Two impacts are proposed because ejections can occur both early and late in the rollover event. In the advanced glazing program, NHTSA performed a series of simulations to recreate three NASS-investigated rollover crashes with ejected occupants.<sup>53</sup> The vehicles were a MY 1991 Toyota pickup, a MY 1986 Toyota Corolla and a MY 1985 Volkswagen Jetta.<sup>54</sup> Vehicle handling simulation software<sup>55</sup> reconstructed the vehicle motion up to the point where the vehicle started to roll. The linear and angular velocity at the end of the vehicle handling simulation was then used as input to a MADYMO<sup>56</sup> lumped parameter model of the vehicle to compute its complete rollover motion. The motion of the vehicle obtained from the MADYMO vehicle model was used as input to a MADYMO occupant simulation. Head and torso velocities of a Hybrid III 50th percentile male driver dummy were calculated for the three rollover simulations.

Table 10 shows the simulation resultant head velocity through the open window at the time of ejection. As indicated in the table, the occupant of the pickup was ejected early (1st 1/4-turn for Toyota truck) while the occupants of the other vehicles were ejected late (last 1/4-turn for Corolla and Jetta) in the rollover event.

<sup>53</sup> "Ejection Mitigation Using Advanced Glazings: A Status Report," November 1995, Docket NHTSA-1996-1782-3, Pg. 6-1.

<sup>54</sup> The circumstances of the Toyota pickup rollover were that the vehicle was traveling at 96 km/h and went into a sharp turn and yaw, which resulted in a rollover. In the case of the Corolla, it was also traveling 96 km/h on a gravel road. The vehicle went out of control and left the road, resulting in roll initiation. The Volkswagen was traveling at 88 km/h when the driver fell asleep and the vehicle left the road. It struck a rock embankment and rolled over.

<sup>55</sup> VDANL software user's manual V2.34, STI, 1992.

<sup>56</sup> MADYMO user's manual V5.1, TNO, 1994.

<sup>49</sup> The ICC is a nonprofit membership association that works on developing a single set of comprehensive and coordinated national model construction codes. <http://www.iccsafe.org/news/about/>.

<sup>50</sup> O'Brian-Mitchell, Bridget M., Lange, Robert C., "Ejection Mitigation in Rollover Events—Component Test Development," SAE 2007-01-0374.

<sup>51</sup> GM explained that their justification for the 100 mm displacement limit is that it represents half the height of the 50th percentile male Hybrid III head.

<sup>52</sup> Each impact would take place on a test specimen (e.g., a curtain) that was not previously subject to an impact test.

TABLE 10—HEAD AND TORSO VELOCITIES OF A HYBRID III 50TH PERCENTILE MALE DUMMY IN 3 ROLLOVER SIMULATIONS

Vehicle	Vehicle ¼ turns	¼ Turns at complete ejection	Restraint use	Head to opening (km/h)	Head to glazing (km/h)	Torso to glazing (km/h)
Toyota PU .....	12	1	Yes .....	20	20	7
			No .....	5	20	16
Toyota Corolla (86) .....	6	6	Yes .....	15	15	11
			No .....	13	13	10
Volkswagen Jetta (85) .....	4	4	Yes .....	14	14	10
			No .....	22	18	16

The agency has also considered other data indicating that very early occupant contact with the window area is possible in rollover crashes. Table 11 gives information on 30 rollover tests the agency performed from the mid-1980s to the mid-1990s. This data set included Rollover Test Device (RTD)

tests, FMVSS No. 208 dolly tests, guardrail tests and pole tests.<sup>57</sup> A film analysis of dummy motion within the vehicles showed that, excluding a pole impact test, occupant contact with the window opening and surrounding area first occurred between 0.16 and 0.88 seconds after the event began.<sup>58</sup> We

note, however, that the majority of these dummies were belted, which means they would be most representative of potential partial ejections. In addition, where the time of window breaking is known, most of these first contacts occurred prior to the window breaking due to roof contact.

TABLE 11—NHTSA FULL VEHICLE ROLLOVER TESTING FILM ANALYSIS

Test No.	Make	Model	MY	Test type	Tilt angle (deg.)	Roll axis (deg.)	Vehicle speed (km/h)	¼-Turns	Total time (sec)
878	Honda	Accord	84	RTD	41	45	33.8	2	1.29
888	Chevrolet	Celebrity	82	RTD	41	45	37.0	4	3.58
920	Dodge	Omni	79	RTD	41	45	37.0	2	0.96
939	Mercury	Zephyr	82	RTD	41	60	37.0	2	2.08
1255	Ford	Bronco	88	RTD	30	45	37.0	2	1.17
1266	Dodge	Caravan	88	RTD	30	45	48.3	1	0.50
1267	Chevrolet	Pickup	88	RTD	30	45	48.3	4	2.58
1274	Nissan	Pickup	88	RTD	30	45	48.3	6	3.76
1289	Nissan	Pickup	89	RTD	30	45	48.3	2	0.83
1391	Dodge	Caravan	89	RTD	30	45	48.3	8	5.08
1392	Ford	Bronco	89	RTD	30	0	48.3	8	3.60
1393	Nissan	Pickup	89	RTD	30	0	48.3	4	2.35
1394	Nissan	Pickup	89	RTD	30	0	48.3	4	1.33
1395	Pontiac	Grand Am	89	RTD	30	0	48.3	2	1.54
1471	Dodge	Colt	89	RTD	30	90	48.3	2	0.99
1520	Ford	Ranger	88	RTD	30	0	48.3	2	0.75
1521	Dodge	Ram	88	RTD	30	0	48.3	4	1.42
1530	Dodge	Caravan	88	Guardrail	N/A	N/A	96.6	1	N/A
1531	Nissan	Pickup	88	Guardrail	N/A	N/A	96.6	4	N/A
1546	Plymouth	Reliant	81	RTD	41	45	33.8	6	3.00
1851	Volvo	240	91	RTD	30	0	48.3	6	2.50
1852	Volvo	740	91	RTD	30	0	48.3	8	3.00
1925	Nissan	Pickup	90	RTD	30	0	48.3	8	3.04
1929	Nissan	Pickup	90	RTD	30	0	48.3	6	2.25
2141	Nissan	Pickup	90	RTD	30	0	48.3	8	4.25
2270	Nissan	Pickup	89	RTD	30	0	48.3	8	3.50
2514	Ford	Explorer	94	208	23	0	48.3	11	5.50
2553	Ford	Explorer	93	208	23	0	48.3	10	N/A
3012	Ford	Explorer	94	208	23	0	48.3	11	N/A
3635	Ford	Explorer	94	208	23	0	48.3	12	5.17
Analysis of 5+ ¼-turn Tests									
Average .....							47.2	8.3	3.7
Maximum .....							96.6	12	5.5
Average + 2 standard deviations .....							55.2	12.3	5.8

The agency is proposing that the ejection mitigation countermeasure be

first tested at 1.5 seconds after deployment of the ejection

countermeasure. As indicated earlier in this preamble, more than half of the

<sup>57</sup> These tests were done as part of a research program evaluating full scale dynamic rollover test methods, occupant kinematics, and vehicle responses. The RTD tests were similar to the FMVSS No. 208 dolly test except that the vehicle was initially 4 feet off of the ground instead of 9 inches, and hydraulic cylinders were used to push

the vehicle from the cart and produce an initial roll rate. The guardrail tests used a guardrail as a ramp to initiate a vehicle roll. The pole tests rolled a vehicle into a pole. Twenty-four of these were RTD tests on passenger cars, pickups and vans (the RTD testing was not geared towards ejection testing since all of the test dummies were belted), and four were

FMVSS No. 208 dolly tests on Ford Explorers. The test films are available at the National Crash Analysis Center (NCAC) at George Washington University (<http://www.ncac.gwu.edu>).

<sup>58</sup> "Evaluation of Full Vehicle Rollover Films," 2008, Docket NHTSA-2006-26467.

complete ejection fatalities occur when the vehicle rolls 5+ 1/4-turns. As shown in Table 11, restricting the analysis to the tests with 5+ 1/4-turns, the average amount of time to complete 1 full vehicle revolution (4 1/4-turns) was 1.62 seconds with a standard deviation of 0.31 seconds. Thus, the 1.5 second represents a period of time in which one full vehicle revolution occurs in a high-energy rollover event. We also note that at 1.5 seconds into the rollover, roof

contact would likely have occurred, leading to window breaking. Thus, as discussed at section V(e) of this preamble, we are proposing to pre-break the glazing prior to this test.

Additional rationale comes from data obtained from the advanced glazing program (see Table 12, *infra*). In that program, NHTSA tested vehicles on the DRF with 5th percentile adult female and 50th percentile adult male test dummies (near and far side).<sup>59</sup> Video

analysis of dummy head impact velocities with the glazing showed that for the 5th percentile female far side occupant, the time to glazing impact after the DRF began rotating was between 1.3 and 1.8 seconds, which was in the range of two to three 1/4-turns of rotation. The peak impact speed was 31 km/h. Table 12 shows the estimated velocities for the near and far side dummies.

TABLE 12—DRF TESTING RESULTS

Dummy	Impact speed (km/h)		Far side impact time (sec.)	Far side impact 1/4 turns
	Near side	Far side		
5th Female .....	14	31	1.3–1.8	2–3
50th Male .....	18	29	.....	.....

The agency is also proposing that ejection mitigation countermeasures be tested towards the end of a rollover. Data indicate that occupants could impact the window opening as late as 6 seconds after initiation of a rollover involving 5+ 1/4-turns. The last three rows of Table 11, *supra*, show the average and maximum number of 1/4-turns and the total time of rollovers involving 5+ 1/4-turns.<sup>60</sup> This set of data contains 14 tests (highlighted in table). The average and maximum number of 1/4-turns are 8.3 and 12, respectively. The average plus two standard deviations is 12.3 turns. Thus, 12.3 1/4-turns is the 98th percentile value for this subset of data. The average and maximum times to complete the entire rollover event were 3.7 and 5.5 seconds, respectively. The 98th percentile value was 5.8 seconds, which is not much different than the maximum time for the entire data set, which was 5.5 seconds.

Other information we considered also supported a 6-second impact time. The data set provided in Table 11, *supra*, showed the vehicle with the longest rollover time (5.5 seconds) in the FMVSS No. 208 dolly test rolled eleven 1/4-turns. NASS-CDS shows that rollovers with eleven 1/4-turns account for about 90% of rollovers with fatal complete ejection, *i.e.*, 10% of rollovers with fatal complete ejections have more than eleven 1/4-turns. This does not mean that rollover crashes with eleven 1/4-turns only take 5–6 seconds. Five to

six seconds may be a conservative assumption for this many 1/4-turns for some types of rollover. The FMVSS No. 208 dolly test has a very quick rollover initiation (high initial roll rate); the beginning of the rollover is well defined. However, the test only represents about 1% of field crashes.<sup>61</sup> The vast majority of field cases are soil and curb trip crashes. Soil trips involve high lateral deceleration in combination with low initial roll rates. Ideally, the curtain air bag should deploy in this early phase when the roll rate is still low but the occupant is moving towards the window due to the lateral deceleration. The rollover has a slow initiation, leading to a need for longer inflation. Therefore, some rollover crashes with less than eleven 1/4-turns may have 5–6 second roll times. A factor that the agency also considered in determining the time delay for the lower speed impact was the practicability of curtains staying inflated for this length of time. Ford stated that its “Safety Canopy” system stays inflated for six seconds.<sup>62</sup> GM has reportedly stated that its side curtain air bags designed for rollover protection maintain 80 percent inflation pressure for 5 seconds.<sup>63</sup>

2. Speed at Which Occupants Impact or Move Through the Window Opening

This NPRM proposes that the impactor should strike the window opening countermeasure at a speed of 24 km/h (after a 1.5 second time delay

after deployment of the countermeasure) and at 16 km/h (after a 6 second delay). The 24 and 16 km/h values are based on several analyses, discussed below, of speeds at which occupants impact or move through the window opening, including analysis of accident data, computer simulations and test films of rollover crashes.<sup>64</sup> In addition, the agency notes that the 24 km/h impact speed is consistent with the impact speed of FMVSS No. 201, “Occupant protection in interior impact” (49 CFR 571.201). FMVSS No. 201 uses a free-motion headform with a 4.6 kg mass to strike vehicle upper interior locations including areas around side window openings. The impact speed for these tests is 24 km/h.<sup>65</sup>

Accident Data

In the analysis of accident data, the agency investigated side impact accident data to determine the ΔV of the crashes in which near side impact occupants were completely ejected. This data is depicted in Figure 3, which shows the cumulative percentage of near side impact occupants completely ejected, by impact ΔV. This graph represents 15,062 occupant ejections weighted from 704 NASS ejection cases. The range of the ΔV was 2 to 55 km/h. With regard to the proposed impact test speeds of 16 and 24 km/h, 47.6 percent of the near side impact occupants were completely ejected at ΔVs at or below 16 km/h, while 65.5 percent of the

<sup>59</sup> Duffy, S., “Test Procedure for Evaluating Ejection Mitigation Systems,” 2002 SAE Government/Industry Meeting.

<sup>60</sup> As earlier, more than half of the complete ejection fatalities occur when the vehicle rolls 5+ 1/4-turns.

<sup>61</sup> Viano, *supra*.

<sup>62</sup> [http://media.ford.com/article\\_display.cfm?article\\_id=6447](http://media.ford.com/article_display.cfm?article_id=6447)

<sup>63</sup> “Who Benefits From Side and Head Airbags?” (<http://www.edmunds.com/ownership/safety/articles/105563/article.html>).

<sup>64</sup> It is noted that the DRF test data presented above that showed far side occupant velocities of

approximately 30 km/h (Duffy, “Test Procedure for Evaluating Ejection Mitigation Systems”) also support the proposed test speeds.

<sup>65</sup> The 24 km/h speed was chosen in part because it is the average speed at which the onset of AIS 2 and AIS 3 injuries are likely to occur.

occupants were ejected at ΔVs at or below 24 km/h.

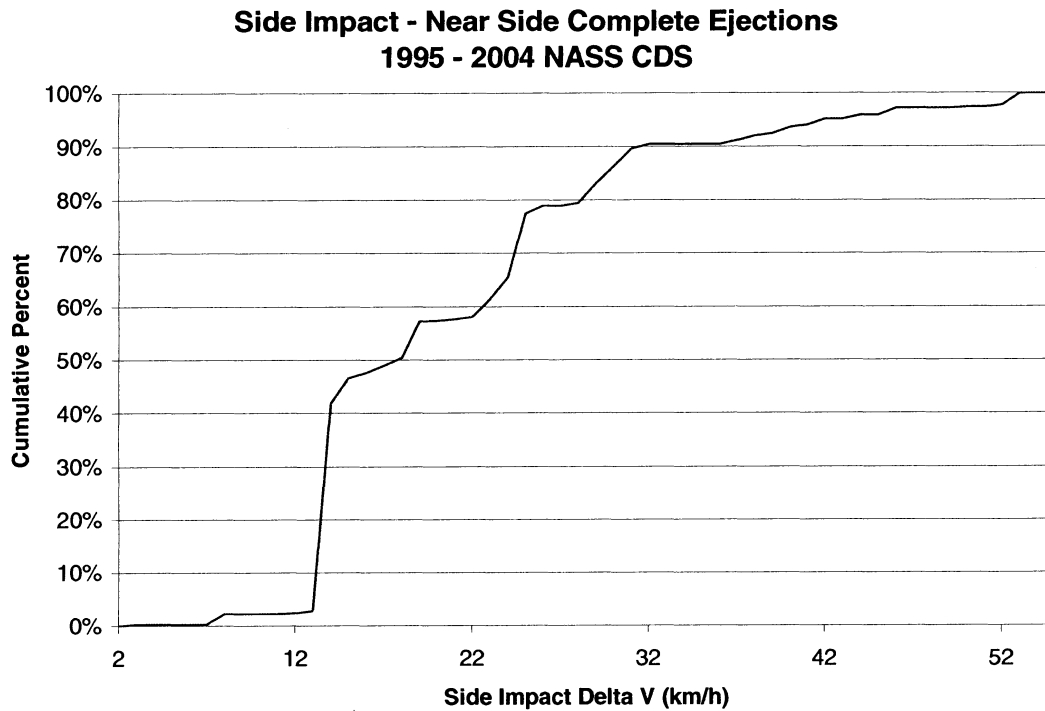

**Figure 3 – Cumulative Percentage of Completely Ejected Occupants in Side Impacts by Impact Delta V. (15,062 weighted ejections from 704 ejection cases.)**

**Computer Simulations**

NHTSA analyzed MADYMO simulations of the real-world rollovers of the Toyota pickup, Toyota Corolla and Volkswagen Jetta, *supra*. As shown in Table 10, *supra*, the computed resultant maximum head and torso velocities at contact with the intact glazing for the unejected occupant indicated a maximum head speed into the window openings of 22 km/h. The maximum head velocity was 22 km/h

for the Jetta unrestrained occupant into the window opening. The maximum torso velocity was 16 km/h, also for the unrestrained Jetta occupant.

**Film Analyses of Full Vehicle Rollover Tests**

In the early 1990’s the agency reviewed 23 of 28 full-scale rollover tests performed in the 1970s–1990s to find any cases of occupant to side glazing impact and to determine the

contact velocities. In seven of these tests, the occupant was observed striking the side glazing with either the head or shoulder. As shown in Table 13, a film analysis was conducted to measure the velocity of the impacts.<sup>66</sup> The average impact velocity measured was 8.6 km/h. Maximum and average head velocities were 17.0 km/h and 10.3 km/h, respectively. Maximum and average shoulder velocities were 8 km/h and 6.3 km/h, respectively.<sup>67</sup>

**TABLE 13—FILM ANALYSIS OF NHTSA ROLLOVER TESTS**

Test #	Make	Model	Test type	Vehicle test speed (km/h)	Occupant impact speed (km/h)	Contact point
878	Honda	84 Accord	RTD	33.8	8.0	Shoulder.
No test #	Dodge	Aries	Guardrail	96.6	16.0	Head.
888	Chevrolet	82 Celebrity	RTD	37.0	6.5	Shoulder.
No test #	Ford	Pinto	Dolly	27.4	2.5	Head.
No test #	Dodge	Reliant	RTD	33.8	4.5	Shoulder.
1520	Ford	88 Ranger	RTD	48.3	5.8	Head.
1522	Nissan	88 Pickup	Pole	48.3	17.0	Head.
Average					8.61	

<sup>66</sup> The analysis is limited by the fact that a single camera was used to determine the velocities.

<sup>67</sup> These measurements compare very closely to the measurements reported in DOT HS476–PM–83–

25. This report evaluated 48 FWHA rollover tests involving passenger cars. In these tests, they found six occupant/glazing impacts (5 head, 1 shoulder). An average impact velocity of 10.9 km/h was

measured. Maximum and average head velocities were 17.8 km/h and 11.3 km/h, respectively. The only measured shoulder velocities were 8 km/h and 8.7 km/h.

Based on the above information, the agency is proposing two impact speeds and time delays. NHTSA requests comment on the appropriateness of the impact speeds and of the time delay for both the high and low speed impacts. If alternative impact speeds and/or time delays are suggested, what are the rationale and data supporting that suggestion?

3. Alternative Testing of Only One Target Position at Higher Speed

The agency proposes to subject all four target locations (per window opening) to the 16 km/h (6 second time delay) impact, but requests comments on whether to test all four target locations with a 24 km/h (1.5 second time delay) impact or just the location with the greatest displacement in the 16 km/h impact. The latter approach would reduce the test burden per window opening from eight targets to five. Our analysis of available data shows that there appears to be a correlation between the displacement results for the 24 km/h and the 16 km/h impacts, particularly for the target location with the greatest displacement. That is, the weakest point in the countermeasure (curtain) that allows the most displacement of the headform could be the same for the 24 km/h impact as for the 16 km/h impact. If the weakest point in the countermeasure is the same for each impact test, it may be possible to reduce the number of tests for one of the impact speeds to a single location. If a correlation exists, an approach the agency could take would be to first determine the displacement at each target location for the 16 km/h (6 second time delay) impact and rank the displacement results from largest to smallest. The agency would then subject only the target with the largest displacement to the 24 km/h (1.5 second delay) second impact. Under this scenario, if the weakest target passes the 24 km/h test, it would be reasonable to assume that the other targets would also have displacements under 100 mm in 24

km/h test. If the weakest target fails the 24 km/h test, the vehicle would fail the requirements of the FMVSS proposed today and there would not be a need to test the other targets.

There are test data demonstrating that the target locations with the most displacement at each test speed are generally the same, but the data are limited. Table 14 shows the impactor displacement results for the MY05 Infinity FX35 (front window), the Zodiac prototype on a Navigator (front window), a TRW prototype on a CK (front window), the MY06 Durango (second row window), and the MY05 Honda Odyssey (second row window). Table 15 shows the displacement rank for each target location and vehicle, from most displacement to least displacement.

For the MY05 Infinity FX35, in the 24 km/h test, the largest and smallest displacements are A1 and A4, respectively. For the 16 km/h test of the Infinity, the ascending displacement ranking is A1, A3, A2 and A4. However, for the 24 km/h test, three trials were performed at A2 and A3 and there is significant overlap in the displacement data. The average displacement plus or minus one standard deviation is shown in the table. In fact, there is no statistically significant difference between the average results of 97 mm at A2 and 95 mm at A3. For the Zodiac prototype data, the ranking of the displacement data at both impact speeds is A1, A3, A2 and A4. For the TRW prototype, the ranking is also identical at both speeds, but the ranking is A1, A2, A3 and A4, which is different from the Zodiac. The target locations for the Odyssey's largest and smallest displacements (A1 and A4, respectively) are the same in the 16 km/h tests as for the 24 km/h impacts.

For the second row window data, the MY06 Durango ranks the displacement at both test speeds as B3, B2, B4 and B1, in ascending order. However, at 24 km/h there is very little separating the displacements at each location. The MY

05 Honda Odyssey has the displacement ranking at the 24 km/h test of B4, B2, B3, and B1. However, for the 16 km/h test the displacement ranking is B2, B3, B4 and B1.

In general, this very limited data set shows a consistency in the displacement results for each impact test speed, particularly for the location of greatest displacement for the front window (A1). For the second row window, the Dodge Durango had consistent results, but the Honda Odyssey did not.

We note that this alternative of performing a single 24 km/h impact at the target that gives the largest displacement in the 16 km/h impact has not been analyzed in the Preliminary Regulatory Impact Analysis (PRIA). However, this does not mean there would be no difference in cost or safety benefits. Rather, assessing this difference would require sufficient data to determine the probability of having a 24 km/h impact displacement greater than 100 mm at some location other than the location of greatest displacement at 16 km/h. We do not have sufficient data for such an assessment.

Comments are requested on whether the 24 km/h impact should only be conducted on the target location with largest displacement in the lower speed test. If results for multiple targets at 16 km/h are within the variance for the test, which target should be selected for the 24 km/h test? The agency's supporting documents for this NPRM estimate the likely test burdens associated with the two approaches. The agency estimates that the restricted testing approach would reduce the number of tests to determine full compliance by 38 percent, while reducing the costs of testing by 8 percent. Please comment on the potential advantages and disadvantages of each method and how the agency might best balance both the safety and potential test burdens.

TABLE 14—DISPLACEMENTS FOR VEHICLE WINDOWS WHERE ALL TARGETS WERE IMPACTED [mm]

	Position A1	Position A2	Position A3	Position A4
24 km/h—1.5 sec. Delay:				
05 Infinity FX35 .....	124	97 ± 14.5	95 ± 11.0	53
Zodiac Prot. On Navigator .....	147 ± 4.9	54	99 ± 4.2	23 ± 2.1
TRW Prot. On CK w/lam .....	181 ± 1.4	21	-26 ± 0.0	-29 ± 5.7
16 km/h—6 sec. Delay:				
05 Infinity FX35 .....	85	21	39	9
Zodiac Prot. On Navigator .....	135	49	80 ± 2.1	-0.2
TRW Prot. On CK w/lam .....	80	-3	-44	-67
	Position B1	Position B2	Position B3	Position B4

TABLE 14—DISPLACEMENTS FOR VEHICLE WINDOWS WHERE ALL TARGETS WERE IMPACTED—Continued  
[mm]

	Position A1	Position A2	Position A3	Position A4
24 km/h—1.5 sec. Delay:				
05 Honda Odyssey .....	71 ± 8.5	152	80	193
06 Dodge Durango .....	76	86	91	82
16 km/h—6 sec. Delay:				
05 Honda Odyssey .....	12	121 ± 0.7	55	28
06 Dodge Durango .....	3	36	71	18

TABLE 15—DISPLACEMENT RANK (FROM LEFT TO RIGHT, MOST DISPLACEMENT TO LEAST DISPLACEMENT), FOR EACH VEHICLE AND TARGET LOCATION

Vehicle	16 km/h—6 sec. delay	24 km/h—1.5 sec. delay
05 Infinity FX35 .....	A1, A3, A2, A4 .....	A1, A2, A3, A4.
Zodiac Prot. on Navigator .....	A1, A3, A2, A4 .....	A1, A3, A2, A4.
TRW Prot. on CK w/lam .....	A1, A2, A3, A4 .....	A1, A2, A3, A4.
05 Honda Odyssey .....	B2, B3, B4, B1 .....	B4, B2, B3, B1.
06 Dodge Durango .....	B3, B2, B4, B1 .....	B3, B2, B4, B1.

*d. Locations Where the Device Would Impact the Ejection Mitigation Countermeasure To Assess Efficacy*

1. Occupants Are Mainly Ejected Through Side Windows

NHTSA analyzed 1997 to 2005 NASS CDS data files to determine the injury and fatality distribution by ejection

routes.<sup>68</sup> Table 16 shows the MAIS 1–2, MAIS 3–5 and fatality distribution of ejected occupants by eight potential ejection routes.<sup>69</sup> Ejection through side windows constitutes the greatest part of the ejection problem. There were 18,353 MAIS 1–2 injuries, 5,271 MAIS 3–5 injuries, and 6,174 fatalities for occupants ejected through side

windows. Table 17 gives the percentage of the total at each injury level. The side window ejections comprise 68 percent of all ejected MAIS 1–2 injuries, 47 percent of MAIS 3–5 injuries, and 61 percent of all ejected fatalities. Because of these data, NHTSA focused on the safety problem posed by side window ejections.

TABLE 16—OCCUPANT INJURY AND FATALITY COUNTS BY EJECTION ROUTE IN ALL CRASH TYPES  
[Annualized 1997–2005 NASS, 2005 FARS]

Ejection route	MAIS 1–2	MAIS 3–5	Fatal
Row 1 Window .....	15,797	4,607	5,209
Row 2 Window .....	2,533	621	906
Row 3 Window .....	23	43	59
Windshield .....	1,923	1,565	1,155
Backlight .....	1,625	1,677	515
Sun Roof .....	1,127	305	237
Other Window .....	1	51	0
Not Window .....	3,870	2,411	2,068
Subtotals:			
All Side Windows .....	18,353	5,271	6,174
Total .....	26,899	11,280	10,149

TABLE 17—OCCUPANT INJURY AND FATALITY PERCENTAGES BY EJECTION ROUTE IN ALL CRASH TYPES  
[Annualized 1997–2005 NASS, 2005 FARS]

Ejection route	MAIS 1–2 (percent)	MAIS 3–5 (percent)	Fatal (percent)
Row 1 Window .....	58.7	40.8	51.3
Row 2 Window .....	9.4	5.5	8.9
Row 3 Window .....	0.1	0.4	0.6
Windshield .....	7.1	13.9	11.4
Backlight .....	6.0	14.9	5.1

<sup>68</sup> All crash types are included, but the counts are restricted to ejected occupants that were injured. In addition, in NASS CDS the ejection route for side windows is only explicitly coded for the front (Row 1 Window) and rear (Row 2 Window). The third and higher row side window ejections should be coded as “other glazing.” This is because there are specific codes available for coding roof glazing,

windshield and backlight. However, when extracting NASS cases of known ejections through “other glazing,” 17 unweighted occupants were observed. A hard copy review of these cases showed that 9 were known 3rd row side window ejections, but five cases were miscoded. Four were actually backlight ejections and one was a sunroof

ejection. The known 3rd row ejections were recoded as “Row 3 Window” ejections.

<sup>69</sup> The “Not Window” category captures ejected occupants that did not go through a glazing area. This might have been an open door or an area of vehicle structure that was torn away during the crash.

TABLE 17—OCCUPANT INJURY AND FATALITY PERCENTAGES BY EJECTION ROUTE IN ALL CRASH TYPES—Continued  
[Annualized 1997–2005 NASS, 2005 FARS]

Ejection route	MAIS 1–2 (percent)	MAIS 3–5 (percent)	Fatal (percent)
Sun Roof .....	4.2	2.7	2.3
Other Window .....	0.0	0.5	0.0
Not Window .....	14.4	21.4	20.4
Subtotals:			
All Side Windows .....	68.2	46.7	60.8
Total .....	100.0	100.0	100.0

2. The Requirements Would Apply to Side Windows Adjacent to First Three Rows

NHTSA evaluated crash data to assess which window, by row, the above injured and killed occupants were ejected through. Table 18 provides the counts of the injured and killed side window ejected occupants by the window row they were ejected through, ejection degree (complete or partial) and restraint condition for the target

population of this rule. Table 19 shows the same data as a percentage of total side window ejected fatalities, MAIS 3–5 and MAIS 1–2 injuries. The first row (row 1) windows provide the ejection route for the most injured and killed occupants. There were 2,459 fatalities and 2,243 MAIS 3–5 injuries that were unbelted and completely ejected through the row 1 windows. The greatest number of fatally ejected occupants (3,671) went through the row 1 window. This represents 83 percent of

all side window ejected fatalities. With regard to injuries, 3,735 (88 percent) MAIS 3–5 and 11,016 (87 percent) MAIS 1–2 injured occupants went through the row 1 windows. Ejection routes through row 1 and row 2 windows accounted for more than 99 percent of fatal and 98 percent of MAIS 3–5 completely ejected and unbelted occupants. These data show a compelling safety need to apply the ejection mitigation standard to row 1 and row 2 windows.

TABLE 18—DISTRIBUTION OF TARGET POPULATION BY EJECTION ROW AND INJURY LEVEL BY EJECTION DEGREE AND BELT USE

[Annualized 1997–2005 NASS, 2005 FARS]

Ejection degree	Belted	Row 1			Row 2			Row 3		
		MAIS 1–2	MAIS 3–5	Fatal	MAIS 1–2	MAIS 3–5	Fatal	MAIS 1–2	MAIS 3–5	Fatal
Complete .....	Yes .....	92	16	69	12	40	0	0	30	0
Complete .....	No .....	3,968	2,243	2,459	1,484	324	588	22	7	38
Partial .....	Yes .....	4,464	1,086	526	58	42	45	0	7	0
Partial .....	No .....	2,492	391	617	119	64	53	0	0	0
Total .....	.....	11,016	3,735	3,671	1,673	471	686	22	43	38

TABLE 19—DISTRIBUTION OF TARGET POPULATION BY EJECTION ROW AND INJURY LEVEL BY EJECTION DEGREE AND BELT USE, AS A PERCENTAGE OF TOTALS AT EACH INJURY LEVEL

[Annualized 1997–2005 NASS, 2005 FARS]

Ejection degree	Belted	Row 1			Row 2			Row 3		
		MAIS 1–2 (percent)	MAIS 3–5 (percent)	Fatal (percent)	MAIS 1–2 (percent)	MAIS 3–5 (percent)	Fatal (percent)	MAIS 1–2 (percent)	MAIS 3–5 (percent)	Fatal (percent)
Complete .....	Yes .....	1	0	2	0	1	0	0	1	0
Complete .....	No .....	31	53	56	12	8	13	0	0	1
Partial .....	Yes .....	35	26	12	0	1	1	0	0	0
Partial .....	No .....	20	9	14	1	2	1	0	0	0
Total .....	.....	87	88	84	13	11	16	0	1	1

We would also apply the standard to row 3 windows. All light vehicle (GVWR 4,536 kg (10,000 lb) or less) rollover occupants in the target population for this proposal were ejected through the windows of the first 3 rows. Third and higher row windows are not specifically coded as ejection routes in NASS, so the “other” window

categories were reviewed. These categories contained only a limited number of 3rd row window ejections (about 1 percent of fatalities and MAIS 3–5 injuries). While the percentage of ejection through the third and higher rows is small, this might be a reflection of the very few light vehicles with more than three rows and the low occupancy

in third and higher rows. NHTSA is concerned that in a crash, an unbelted occupant could be ejected from the 3rd row window opening. As discussed in IV(b)(2) of this preamble, the agency has observed laboratory DRF tests in which an unbelted dummy was initially prevented from ejection by a side curtain, but was eventually ejected



when it slid to an opening in the curtain. Further, with substantial numbers of 3-row vehicles used as passenger vehicles, applying the standard to row 3 as well as rows 1 and 2 windows would be consistent with the SAFETEA-LU mandate "to establish performance standards to reduce complete and partial ejections of vehicle occupants from outboard seating positions."

In addition, it appears practicable for manufacturers to meet ejection mitigation requirements applying to the row 3 windows. There are a number of current OE air bag curtains that cover rows 1, 2 and 3 windows, such as the 2005–2007 MY Honda Odyssey, 2006 Mercury Monterey, 2007 Chevrolet Tahoe, and 2007 Ford Expedition.

Less can be said about the practicability of air bag curtain coverage beyond three rows of seating. Vehicles in this category are primarily large vans with more than 10 seating positions and are in the bus category. We do not believe that manufacturers have installed air bag curtains that cover beyond the third row windows in vehicles that have more than three rows. Thus, we would not apply the standard to windows for row 4+.

Out of concern to properly assess the cost impact of this rulemaking, we are also proposing to limit the testable area of window openings extending rearward past the designated seating positions of the first three rows. This NPRM proposes that, for vehicles with 3 rows, for any side window opening that extends rearward of a 3rd row forward-facing designated seating position (DSP), the rearward edge of the testable side window opening would be bound by a transverse vertical vehicle plane 600 mm (approximately 24 inches) behind the seating reference point (SgRP) of the 3rd row DSP. If the 3rd row designated seating position is adjustable to a non-forward facing orientation, the target area extends to 600 mm behind the rearmost portion of the seat when the seat is adjusted to the most rearward position (with respect to the vehicle) and the seat cushion and

seat back are in the manufacturer's design position. So if a vehicle's third row seat has both a forward and a rearward facing position, the testable area would be determined as specified above. The final target area would be the largest area as defined under either of these conditions, *i.e.*, (1) by the SgRP of the forward facing seat, or (2) the most rearward part of the non-forward facing seat. This limitation of testable area would also be applied to the 2nd row window in two-row vehicles and 1st row window in one-row vehicles. The limitation would primarily affect sport utility vehicles (SUVs) with two rows of seating and side window areas adjacent to the rear cargo area. While it is not impossible for unbelted occupants to be partially or completely ejected through this area, we believe that ejection through a non-adjacent opening more than 600 mm from the occupant's SgRP is less likely. We note that FMVSS No. 201 has a similar exclusion in S6.3 that excludes impact targets 600 mm rearward of the rearmost SgRP. We also note that changes to the seating configuration for vehicles with removable or stowable seats must be considered in the determination of the rearward limit of the testable area. We propose that the seating configuration that generates the largest testable area would be used.

This NPRM proposes a definition of the term "row," since the proposed regulatory text frequently refers to the term in describing the applicability of the ejection mitigation requirements. While the definition of the term is generally understood, under the proposed definition we would clarify that a single seat could constitute a "row." The proposed definition of "row" would state: "Row" means a set of one or more seats whose seat outline does not overlap with the seat outline of any other set of seats, when all seats are to their rearmost normal riding or

driving position, when viewed from the side.<sup>70</sup>

In consideration of the above definition of "row" we believe it is necessary to define "seat outline." The proposed definition of "seat outline" would state: "Seat outline" means the outer limits of a seat projected laterally onto a vertical longitudinal vehicle plane.

We believe that the definition is needed to address potential questions about vehicles that appear in one seating configuration to have 2 conventional rows of seating, but which have a seat or seats in a row (*e.g.*, the 2nd row) that are capable of being adjusted forward or rearward independently from other seats in its row. For example, suppose a seat in the 2nd row can move rearward such that it can occupy a position occupied by a seat traditionally considered to be in the 3rd row. NHTSA tentatively believes that a reasonable way of addressing this issue is as follows. First, the vehicle seats must be adjusted such that they are in the SgRP position. This places each seat in the rearmost normal driving or riding position. The transition for a seat being in one row as opposed to another is the overlapping of the side view "seat outline" of the seats. Seats whose seat outlines overlap are considered to be in the same row.

To illustrate, Figure 4 shows the top and side view of a two row vehicle, with two seats in the front row and three seats in the 2nd row. All seats are assumed to be adjusted such that the design H-point coincides with the SgRP. Figure 5 is another five-seat vehicle that has a more rearward position for the 2nd row center seat than in Figure 4. However, looking at the side view, there is still overlap between the outline of the rear center seat and the outboard 2nd row seats. Thus, by our proposed definitions this is still a two-row vehicle.

**BILLING CODE 4910-59-P**

<sup>70</sup> Stated differently, the seats are adjusted such that their design H-point coincides with seating reference point.

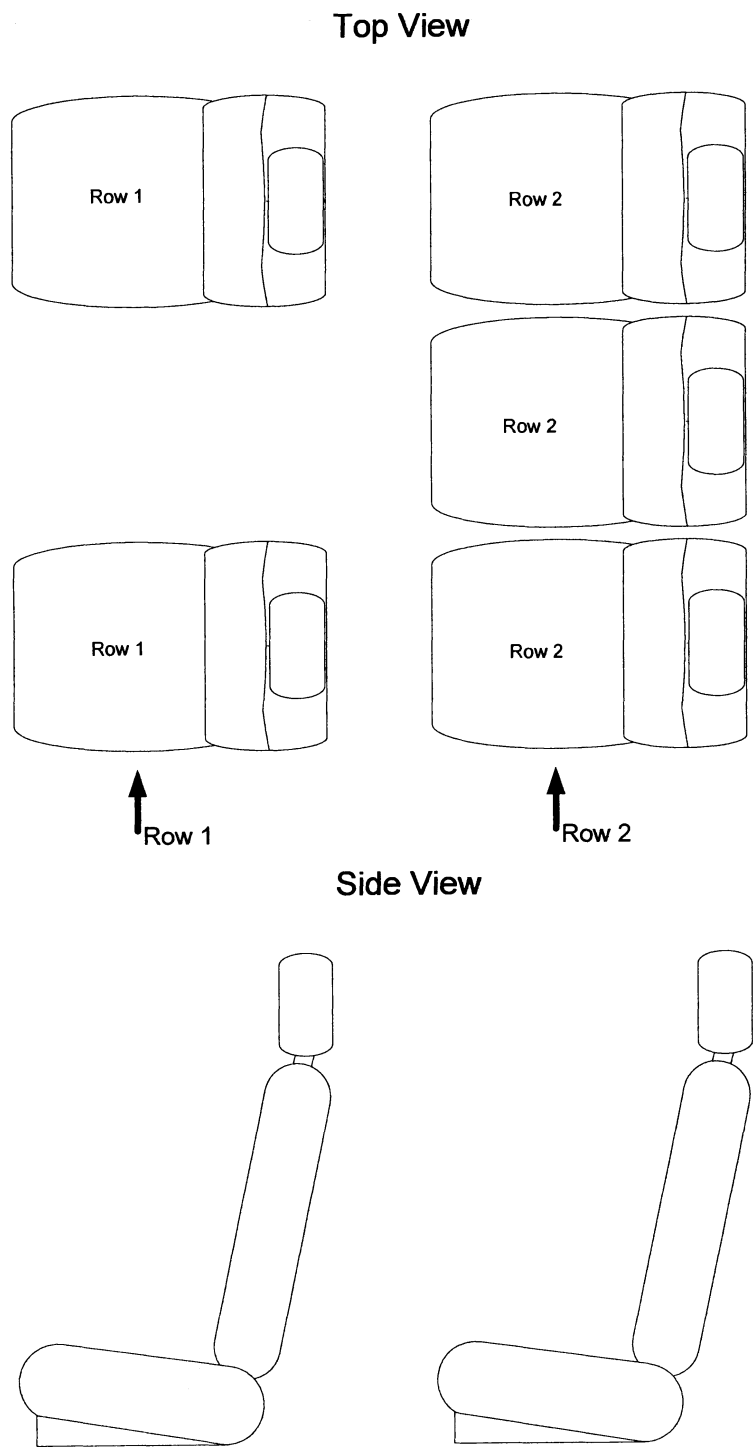

**Figure 4 – Two row vehicle with all 2<sup>nd</sup> row seats aligned. All seats set to the SgRP position.**

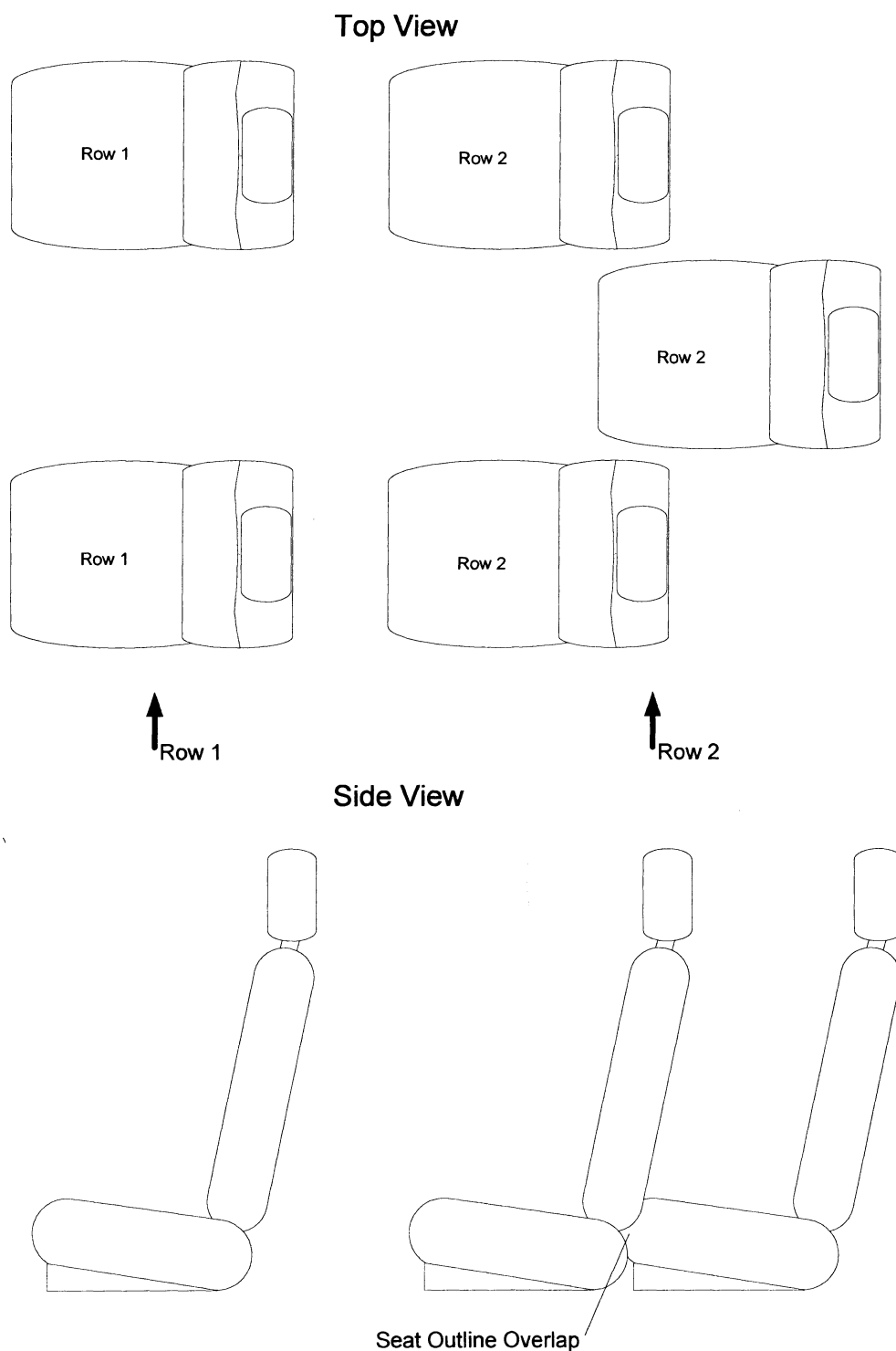

**Figure 5 – Two row vehicle, with the middle seat of the 2<sup>nd</sup> row having a small overlap with the outboard seats. All seats set to the SgRP position.**

**BILLING CODE 4910-59-C**

Comments are requested on the practicability, cost and potential benefit of extending application of the ejection mitigation requirements to rows beyond the 3rd row. Please also comment on the appropriateness and practicability of the 600 mm limitation, and on whether the

value should be increased or decreased. Comments are also requested on the proposed definition of “row” and the implications of the definition on other FMVSSs, *e.g.*, FMVSS No. 225, “Child restraint anchorage systems.” Standard No. 225 requires vehicles that have “3

or more rows” to have a child restraint anchorage system in the “second row” (S4.4(a)(1), 49 CFR 571.225).

**3. Four Targets per Glazing Area**

NHTSA seeks to assure in a reasonable manner that any ejection

mitigation countermeasure provides the full coverage of potential ejection routes. The cost and burden of testing increases as the number of target locations increases, or as less specificity is provided in the test procedures identifying the target location. The agency has tentatively decided to limit the number of target locations per glazing area to four. In examining current side window designs, four targets appear sufficient to assure side window opening coverage for window designs. The targets would be less than four if the window area is small enough to create significant overlap in the target locations.

As discussed earlier in this preamble at section IV(e), a comparison of the

results of the DRF tests and impactor tests indicated that if key locations around the perimeter of the window opening were not targeted, an opening could form through which an occupant could be ejected in a rollover. Target A1 (see Figure 6 below, which is replicated below for the convenience of the reader from Figure 1 of this preamble) was the most challenging target in the component test, while A4 was the least challenging. For the 24 km/h (1.5 second time delay) test, the only system that did not exceed the 100 mm criterion at A1 was the Zodiac Prototype on the CK pickup. The data indicate that if target position A1 were not tested, an ejection mitigation curtain could have

displacements of less than 100 mm in the other tests, yet have a hole large enough in a rollover to allow an occupant to be ejected. No displacement at A4 exceeded 76, 73 or 67 mm at 24 km/h, 20 km/h and 16 km/h, respectively. Taken as a whole, A2 and A3 showed similar results to each other for all three test conditions (24 km/h, 20 km/h, and 16 km/h impacts) in that neither was as consistently challenging to meet as A1 nor as easily met as A4. Thus, based upon existing agency tests, passage of point A1 would tend to indicate a satisfactory countermeasure, but some vehicles showed more displacement at A3 than at A1.

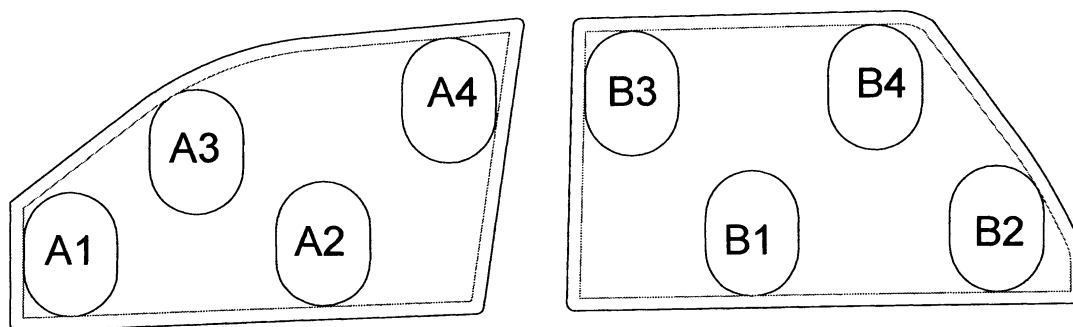

**Figure 6—Target Location Determined by Proposed Method  
(Figure 1 replicated)**

The four targets are similar to those identified by GM in developing that manufacturer's ejection mitigation side curtain air bags. GM indicated that its test procedure targets the front side window opening in three locations: the upper rear corner, the lower front corner and the centroid of the window opening.<sup>71</sup> The first two target locations are very similar to the proposed target location A4 and A1 described in Figure 6 above. GM explained that it identified the upper rear target as a test point because it represents the most frequent impact position in rollover, and because it is at the edge of the rearward seating position and assesses protection for taller occupants. GM believes that the lower front corner test point evaluates the curtain for the forward seating position, assesses the curtain's performance with smaller occupants, and is the location at which the trailing (far side) occupant contacted the window opening in rollover tests. The

centroid position represents the impact location with the least boundary condition support. While NHTSA's proposed targets are similar in location to GM's three targets, the agency tentatively believes that using four targets is preferable to only three targets to better assess how well the curtain covers the perimeter of the window opening.

Comments are requested on whether the FMVSS should specify that any point of the ejection mitigation window curtain will be tested by NHTSA, without limiting the number of target locations or specifying precisely the locations of the targets. The advantage to such an approach is that the agency would be allowed flexibility in choosing where to impact the ejection mitigation curtain, and could choose the location on the curtain that appeared to be the "weakest," thereby assuring that all portions of the curtain would limit head displacement and not just the four target points identified in an FMVSS.

Manufacturers would have to ensure that the curtain passed the performance limits at any point that NHTSA may select, which means that all parts of the

curtain would have to meet the requirements. Further, it is possible that a sufficient assessment of countermeasure effectiveness could be achieved with fewer than four tests per window without decreasing the realized safety benefit.

#### **What Is a "Window Opening"?**

This NPRM proposes a specified procedure for identifying the four targets of each window opening. The procedure is described in the next section and in detail in the Technical Analysis. To objectively describe "window opening," this proposal would generally use the term "daylight opening," as defined in FMVSS No. 201 for openings on the side of the vehicle. The term is defined in FMVSS No. 201 as: "the locus of all points where a horizontal line, perpendicular to the vehicle longitudinal centerline, is tangent to the periphery of the opening. \* \* \*" There is a daylight opening for each separate piece of glazing. For example, a single door may have multiple daylight openings if there are

<sup>71</sup> O'Brian-Mitchell, Bridget M., Lange, Robert C., "Ejection Mitigation in Rollover Events—Component Test Development," SAE 2007-01-0374.

multiple pieces of glazing comprising the side window opening.<sup>72</sup>

Note, however, there would be two differences between the proposed definition and the FMVSS No. 201 definition of daylight opening. First, the proposed definition would state that the above-referenced horizontal line would not only be tangent to the periphery of the opening, but would also include the area 50 mm inboard toward the vehicle centerline from the window glazing interior surface. This provision is intended to account for interior trim or other substantial vehicle structure that might be in the vicinity of the daylight opening, which could restrict the size of the opening through which an occupant could be ejected.

Second, we propose to exclude from the "daylight opening" definition any flexible gasket material or weather stripping used to create a waterproof seal between the glazing and the vehicle interior. The rationale for the exclusion is that the flexible material is unlikely to impede occupant ejection through the opening. This results in keeping the test area as large as possible. In the next paragraph, we discuss a proposal that would specify a 25 mm offset from the daylight opening in determining the testable area. If flexible gasket material or weather stripping were not excluded from the daylight opening definition, the testable area would be further reduced and the impactor targets would be moved even further inward away from the perimeter of the opening. Since we want to keep the target locations close to the opening perimeter to assure full coverage of the ejection mitigation curtain, we have tentatively decided to exclude the flexible material from the daylight opening definition. Comments are requested on the "daylight opening" definition.

Although the determination of daylight opening is made with flexible gasket material or weather stripping removed, we propose that the gasket material be present for the impactor test. Our rationale for having the material present is that conceivably, the material could affect the test results in some situations, and that during real world rollovers it is likely that the flexible gasket material or weather stripping would be present. However, we do not have comparative data between testing with and without the flexible gasket material or weather stripping. Further, we recognize that if the gasket material is removed to determine the daylight opening, specifying that the material is

present on the vehicle for the impactor test will necessitate an extra step in the testing. Therefore, we request comments on whether the impact test should be performed with or without the flexible gasket material or weather stripping.

In specifying how the four targets of a side window opening are located, the test procedure would exclude a portion of the daylight opening. Briefly stated, to identify the four targets, measurements would be taken from a line offset 25 mm from the daylight opening (depicted as the innermost outline of the daylight opening in Figure 6, above). This is the line used to provide the tangent for the placement of the two dimensional projection of the headform as viewed from the lateral vehicle direction. The reason underlying the 25 mm offset for the headform tangent relates to the potential imprecision of the linear impactor. Although the impactor is guided, it is not possible to always have it strike precisely where targeted. As will be discussed later, we are proposing a  $\pm 10$  mm tolerance on the impact location as well as  $\pm 2$  mm for locating the offset line and  $\pm 2$  mm for locating the target tangent to the offset line. Thus, a 25 mm offset from the window daylight opening yields 11 mm of buffer to assure that the impactor will not strike the window frame structure. If the impactor were to strike the window frame structure, the impactor could be at least partially restrained by the window frame structure rather than by only the window curtain and/or other ejection countermeasure.

We are proposing that the location of the offset-line be made by first projecting the daylight opening laterally onto a vehicle vertical longitudinal plane. Then at each point on the projection, a tangent line would be determined. Finally, a point would be located by moving  $25 \pm 2$  mm perpendicular to the point of tangency, in the vehicle vertical longitudinal plane. The set of points determined in this way would constitute the offset-line. Comments are requested on the 25 mm offset value and the method used to determine its location. Is there a simpler method to provide an offset from the daylight opening that is sufficiently objective and repeatable?

#### 4. Method for Determining Impactor Target Locations

The agency developed a method for determining target locations with the following goals in mind:

(1) The test method has to be objective and repeatable so that there would be no ambiguity as to the target locations and

so different testers would put the targets in the same locations;

(2) The method has to result in the placement of targets that are well distributed around the perimeter of the window opening to assure full coverage of the opening by the ejection mitigation countermeasure; and

(3) The method has to be simple and straightforward and suitable for varied window shapes of the vehicles to which the standard applies.

NHTSA believes that the proposed test method meets these goals. The test approach has three main parts. The first part specifies how targets would be identified on front (between A- and B-pillars) and rear windows (rearward of the B-pillar).<sup>73</sup> The test method differs slightly between front and rear windows to account for the distinct shapes of the windows. Front windows typically have a large rearward rake, while rear windows usually either have a forward rake due to the inclination of the rear backlight area or are somewhat rectangular in shape. For front windows, the lower-front and upper-rear portions of the opening have acute angles. For rear windows, particularly the second row in two-row vehicles and the third row in three-row vehicles, the acute angles are on the upper-front and lower-rear part of the opening. The lower acute angle locations are likely to be challenging for any header-mounted air bag curtain and are, therefore, good potential target locations (goal #2, above). These acute angles also provide convenient target locations because there is no ambiguity as to placement of the headform (goals #1 and 3). After conducting this first part of the test approach, the four target locations would be identified on most front and rear windows.

The second part of the test procedure addresses what happens if, after conducting the first part of the test approach, the four targets substantially overlap each other, as would be the case involving smaller than typical rear windows, such as "sail panels" that are installed in the rear of larger rear windows of some vehicles. (These windows are usually triangular in shape.) This part of the test procedure specifies an objective means of eliminating some of the four targets that overlap to avoid redundancy in testing, and describes which targets would be eliminated or considered for elimination

<sup>73</sup> The proposed method of determining target locations is limited to *side* window openings. Thus, all front and rear window locations discussed are on the sides of the vehicle. The front window(s) are adjacent to the first vehicle seating row and the rear window(s) are adjacent to second and third seating rows.

<sup>72</sup> The proposed test procedure has a provision that provides for fewer targets than four for small daylight openings.

and the order in which they would be considered (goals #1 and 2).

The third and final part of the test procedure addresses what happens if, after eliminating some targets pursuant to the second part of the test procedure, too few targets remain to test a daylight opening sufficiently. This part of the procedure involves the reconstituting (adding back in) of targets if, after implementing the second part of the procedure, there are too few targets remaining to evaluate the ejection

mitigation performance of a countermeasure (goal #3).

#### Part 1: Finding the Four Targets

The first step in determining the four impactor target locations would be to find the corners of the daylight opening. The target locations are found by viewing the window from the lateral vehicle direction (y-axis). The corner would be located by using the “target outline” of the impactor face, which would be the x-z plane<sup>74</sup> projection of the ejection headform face, as shown in

Figure 2 of this preamble. The target outline would be the projection of the impactor face in a vehicle vertical longitudinal plane. A corner would be defined as any location within the daylight opening where the impactor target outline is tangent to the offset line (the offset line would be 25 millimeters inside the daylight opening) at two or more points. Figure 7 shows target outlines placed in the corners of the side window daylight opening for the front and rear windows of a two-row vehicle.

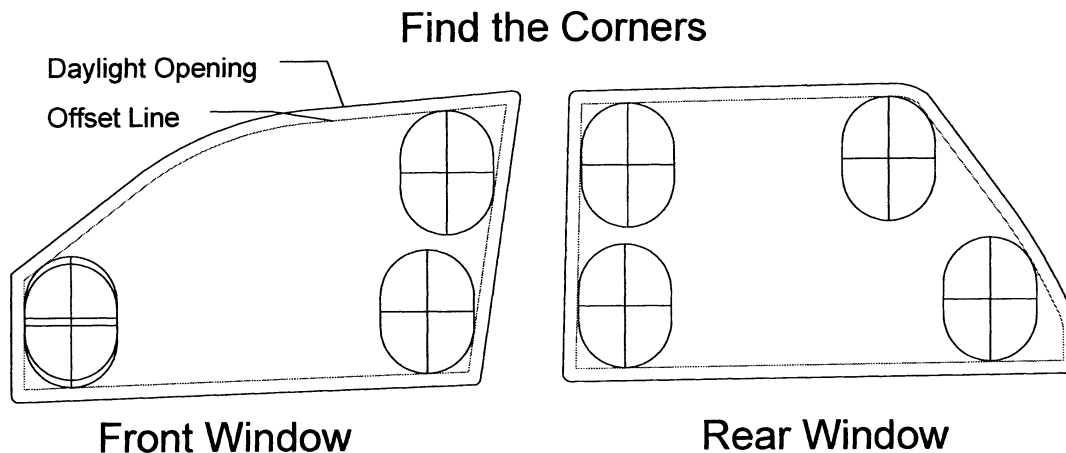

**Figure 7**

The next step in the target location process would be to locate the geometric center<sup>75</sup> of the daylight opening, and then to use the geometric center to separate the opening into four quadrants, *i.e.*, lower-front, lower-rear, upper-front and upper-rear. Next, we would eliminate the target in certain quadrants. For the front window, we would eliminate any target whose center is not within (inclusive of the border between quadrants) the lower-front and upper-rear quadrants. For all rear window openings, we would eliminate any target whose center is not within the upper-front and lower-rear

quadrants (inclusive of the border). We would retain the front window lower front-most and rear window lower rear-most target locations because they are likely to be challenging for any header-mounted air bag curtain and are, therefore, good potential target locations (goal #2, above). These locations also have the advantage of presenting no ambiguity as to placement of the headform (goals #1 and 3), as is also the goal for the front window upper rear-most and rear window upper forward target locations.

The remaining targets are called “primary targets,” and the quadrants in

which they are located are “primary target quadrants.” If there is more than one target left in a primary target quadrant, we would maintain the lowest target in the lower quadrants and the highest targets in the upper quadrants, to ensure that the extremes of the ejection mitigation countermeasure would be tested. If there were no target centers within those quadrants, we would use the target whose center is closest to the quadrant. This process leaves the “primary targets” shown in Figure 8.<sup>76</sup>

<sup>74</sup> The coordinate system convention is—  
x-axis: vehicle longitudinal axis;  
y-axis: vehicle lateral axis;  
z-axis: vehicle vertical axis.

<sup>75</sup> The balance point of an object assuming uniform weight distribution. Later in this section of this document we request comments on an alternative to using the geometric center to separate the window into quadrants.

<sup>76</sup> Geometric center locations shown are for illustration purposes only and may not reflect the actual location for the daylight opening depicted.

## Identify Primary Targets

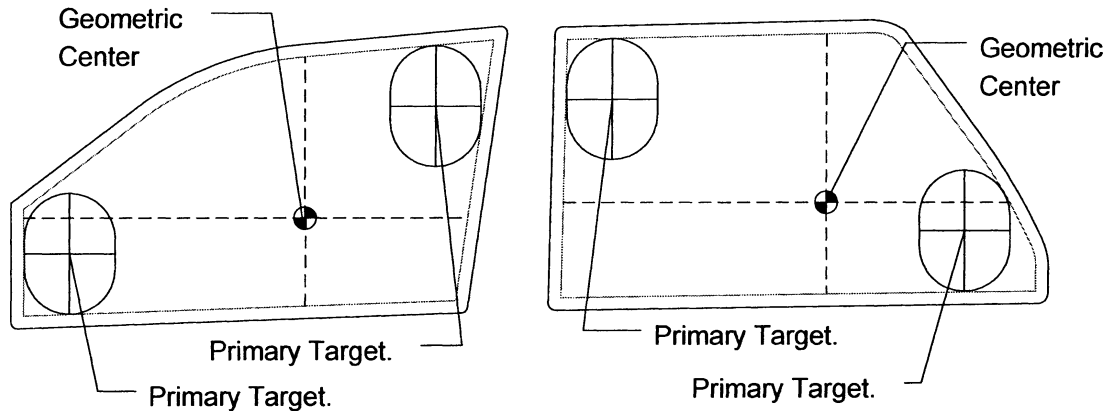

**Figure 8**

The final step in the target location process would be to locate the two additional targets ("secondary targets") for each daylight opening. The two targets would be positioned in reference to the primary targets. To locate the two additional targets, we would measure the horizontal distance between the centers of the primary targets. These distances are shown as A and B for the

front and rear windows in Figure 9, respectively. In order to have targets spaced equally in the fore-aft direction, vertical reference lines would be located at horizontal distances  $A/3$  and  $B/3$  from the primary target locations. For the front window area, a secondary target (the third target) would be centered at a rearward horizontal distance  $A/3$  from the lower-front

primary target and moved vertically upward until contact is made with the offset line. Another secondary target (the fourth target) would be centered at a forward horizontal distance  $A/3$  from the upper-rear primary target and moved vertically downward until contact is made with the offset line.

## Final Target Locations

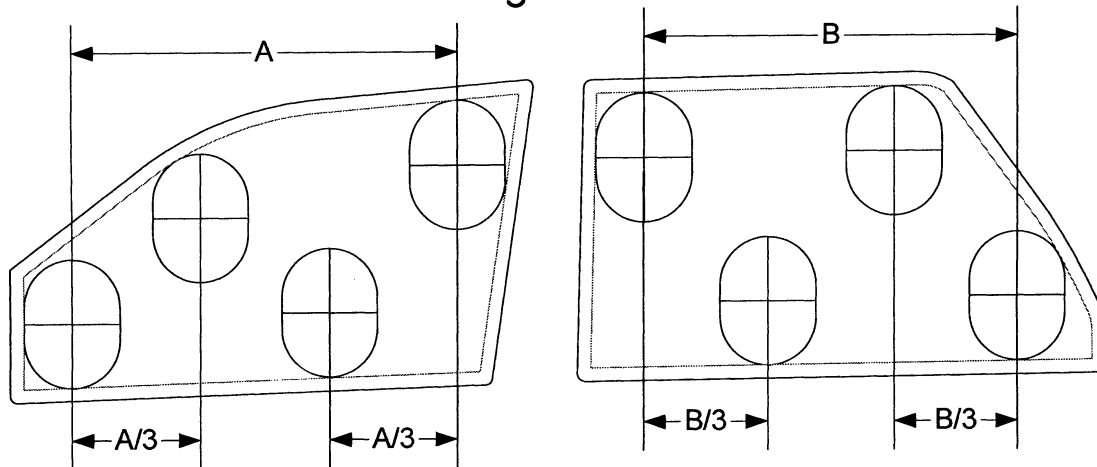

**Figure 9**

For all other side windows, except the front, a secondary target (the third target for these rear side windows) would be centered at a rearward horizontal distance  $B/3$  from the upper-front primary target and moved vertically downward until contact is made with the offset line. Another secondary target

(the fourth for these side windows) would be centered at a forward horizontal distance  $B/3$  from the lower-rear primary target and moved vertically upward until contact is made with the offset line (see Figure 9).

An example of the target identification procedure applied to a

daylight opening that is symmetric about the horizontal axis is provided below in Figure 10. The opening has six corners<sup>77</sup> and is a rear window. Under

<sup>77</sup>Note that although it may appear that there is only a single point of contact for the middle targets



the targeting procedure, the targets located in the lower-front and upper-rear quadrants are eliminated. Because of the symmetry, two of the targets centers are located along the quadrant boundaries. Targets located on a quadrant boundary as shown would be considered by the test procedure to be

in the upper-front and lower-rear quadrants, so these targets would not be eliminated on the basis that they are not in the upper-front and lower-rear quadrants. However, the targets would be eliminated on the basis that they are not the uppermost and lowermost targets in the upper-front and lower-rear

quadrants, respectively. Two primary targets remain as shown in Figure 10b after eliminating the targets as specified; the primary targets are the upper target in the upper-front quadrant and the lower target in the lower-rear quadrant. Finally, the secondary targets are located as shown in Figure 10c.

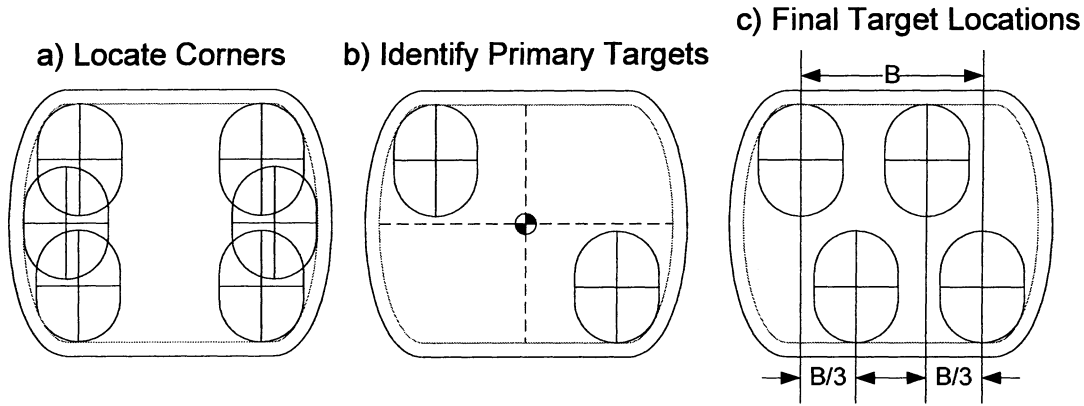

Figure 10

Because of potential daylight opening shapes and sizes, the possibility exists that, once targets are placed in the corners, no target centers are located in one or both of the primary target quadrants. If this occurs, the target whose center is closest to the primary target quadrants is used. Figure 11 shows an example of this. This is a

representation of a rear window, so the primary quadrants are at the upper-front and lower-rear. Note that there are three potential primary targets located at the corners of the window opening. However, only the lower primary quadrant has a target center located within its boundary. The upper primary quadrant has no target center within its

boundary. In this example, the most forward target becomes the second primary target because its center is closest to the boundary of the upper primary quadrant. The procedure for locating the secondary targets remains the same.

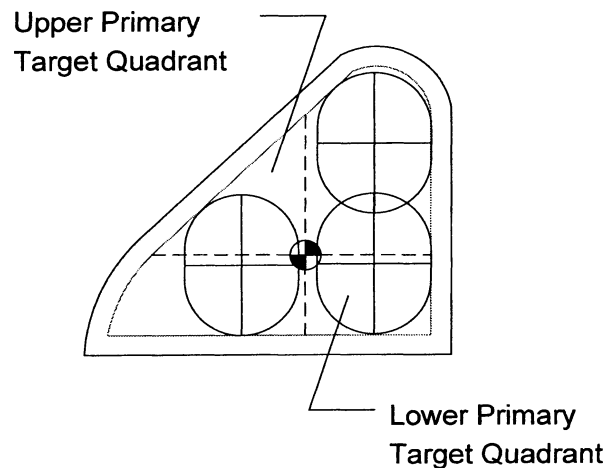

Figure 11

NHTSA requests comments on the proposed method for determining the impactor target locations. Are there

better alternatives than using the geometric center of the daylight opening to determine the window quadrants,

such as dividing the overall length and height of the daylight opening in half?

in Figure 9a, due to the relative curvature of the window and targets, there are two points of contact.

Would such a method be simpler and result in the same final target locations?

NHTSA also requests comment on the orientation of the target outline. Occupant orientation when in contact with the ejection mitigation system may vary; particularly for unbelted occupants. The targeting procedure described above maintains the long axis of the target outline aligned with the vehicle's vertical axis. Should the targeting procedure instead be performed with the target outline's long axis aligned with the vehicle's horizontal axis or some other orientation? We have not studied the sensitivity of the impactor displacement with the target outline orientation. Please provide data on the effect of alternative impactor orientations.

**Part 2: Allowing Fewer Than Four Targets for Small Windows**

The second part of the test procedure addresses what happens if, after conducting the first part of the test approach, the four targets substantially overlap each other, as would be the case involving smaller than typical side rear windows, such as "sail panels" that are installed in the rear of larger rear windows of some vehicles. However, for some two-door passenger cars, these sail panels can be large enough to be impacted. Since the impactor contact surface represents the averaged dimensions of the side and face of a 50th percentile head, a sail panel large enough to fit the impactor outline within the offset line could be the location of a partial head ejection.

This part of the test procedure calls for eliminating some of the four targets to avoid redundancy in testing, and describes which targets would be eliminated or considered for elimination, and the order in which they would be considered. This part involves measuring the horizontal (x-axis) and vertical (z-axis) distances between target centers. If the horizontal distance is less than 135 mm and the vertical distance is less than 170 mm, the agency would eliminate a target. Table 20 identifies which targets are compared, in priority order. In each case, both the target centers must be closer than 135 mm and 170 mm in the x and z directions, respectively, for a target to be eliminated.

TABLE 20—PRIORITY LIST OF TARGET DISTANCES TO BE CHECKED AGAINST HORIZONTAL AND VERTICAL LIMITS

Step	Measure distance of these target centers	Eliminate this target if horizontal and vertical distances are less than 135 mm and 170 mm, respectively *
1	Upper Secondary to Lower Secondary	Upper Secondary.
2	Upper Primary to Upper or Remaining Secondary	Upper or Remaining Secondary.
3	Lower Primary to Lower or Remaining Secondary	Lower or Remaining Secondary.
4	Upper Primary to Lower Primary	Upper Primary.

\* The target centers must be closer than 135 mm and 170 mm in the x and z directions, respectively.

In step 1 of this procedure, we would determine the horizontal and vertical distance between the centers of the secondary targets. If the horizontal distance is less than 135 mm and the vertical distance is less than 170 mm, we would eliminate the upper secondary target. If only one distance is less than the specified value, we would not eliminate the target. In either case, we would proceed to step 2.

In step 2, we would measure the distance between the upper primary target and the upper secondary target (if it survived step 1) or the remaining secondary target. If the horizontal and vertical distances are less than the specified values, the secondary target is eliminated. If only one distance is less than the specified value, we would not eliminate the target. In either case, we would proceed to step 3.

In step 3, the process is repeated, except we would measure the distance between the lower primary target and the lower secondary or to the remaining secondary target. If the horizontal and vertical distances are less than the specified values, the secondary target is eliminated. If only one distance is less than the specified value, we would not eliminate the target.

In step 4, we would measure the distance between the upper primary target and the lower primary target. If

the horizontal and vertical distances were less than the specified values, the upper primary target would be eliminated. If only one distance is less than the specified value, we would not eliminate the upper primary target.

The Technical Analysis accompanying this NPRM provides examples of the target comparison and elimination progression for illustration purposes.

The selection of the 135 mm and 170 mm dimensions is based on the agency's engineering judgment as to what would be excessive overlap between the targets, based on a small sample of window openings. The agency determined that this spacing between targets would ensure a wide and even distribution of targets across the ejection mitigation countermeasure, which effectuates a thorough evaluation of the countermeasure. Each value is approximately 75% of the maximum dimension of the impactor in that direction (170/226 = 75% and 135/177 = 76%).

The target elimination process proposed provides an objective and repeatable means of limiting the overlap between targets while maintaining coverage of the entire window opening. Thus, it is consistent with all of the agency's stated goals for a targeting procedure. The targets that are retained

over those slated for elimination in Table 20 (above), and deemed "priority" targets, are important for the following reasons. NHTSA has given priority to the primary targets over the secondary targets since the primary targets assess the curtain at its extremes: at the foremost bottom portion of the curtain and at the top aft of the curtain, for the case of a front window, and the opposite corners in the case of a rear window. Further, of the two primary targets, the lower primary target has priority over the upper primary. This is because most ejection mitigation curtains now deploy from the roof rail downward, and gaps through which ejections may occur can form between the curtain and the window opening more readily than at locations close to the air bag curtain housing unit at the roof rail. Thus, if only the two primary targets remain after the elimination process, the lower primary target is likely to be the most demanding target in assessing the ability of the curtain to retain occupant excursions. For these reasons, NHTSA tentatively concludes that after the target elimination process is conducted, the lower primary target should prevail.

Finally, under the proposed test method, the long axis of the target outline is aligned with the z-axis. Because of the 25 mm offset, for window openings with a vertical

dimension of less than 276 mm (10.9 inches) no targets will fit in the window opening. The agency is considering rotating the impactor outline 90 degrees and performing the same targeting methodology, in order to fit a target(s) within the window opening.

Comments are requested on the following issues:

- Please comment on the concept of impacting a window in at least one location if it is large enough to fit a target outline within the offset line. Is there a better method of determining if a window opening is sufficiently large to be the site of a partial ejection, and therefore, a reasonable location for impact?

- Comments are requested on the proposed method for reducing the number of target locations for small windows. Specifically, are the 135 mm horizontal and 170 mm vertical limits reasonable?

- Please comment on a strategy of rotating the impactor headform by 90 degrees in the event no targets fit in the window opening when the impactor is oriented with a vertical long axis. If this horizontal impactor orientation results in no target outlines fitting within the window, should the impactor be allowed to be oriented at any angle necessary to fit inside the opening?

### **Part 3: Reconstituting Targets To Get to Three**

If, after running the course of Parts 1 and 2 described above, the window area drops from having four crowded targets to having only two with a relatively substantial separation between them (more than 360 mm), we believe that a target should be reconstituted (added back) between the two. This added target would be centered such that it bisects a line connecting the centers of

the two remaining targets. See drawing on the right in Figure 12 for an illustrated example. In the drawing, the total distance between the remaining targets was 429 mm; the original two secondary targets have been replaced by single target midway between the two primary targets.

The limit for adding back a target is 360 mm of separation between the remaining targets (see Figure 13). The 360 mm limit is based on engineering judgment as to what would be too much gap between targets and allow an ejection portal if the curtain was not sufficiently inflated or taut. Please comment on the proposed method for adding target locations if only two targets remain after the target reduction scheme is followed. Is the 360 mm distance between the remaining targets reasonable?

**BILLING CODE 4910-59-P**

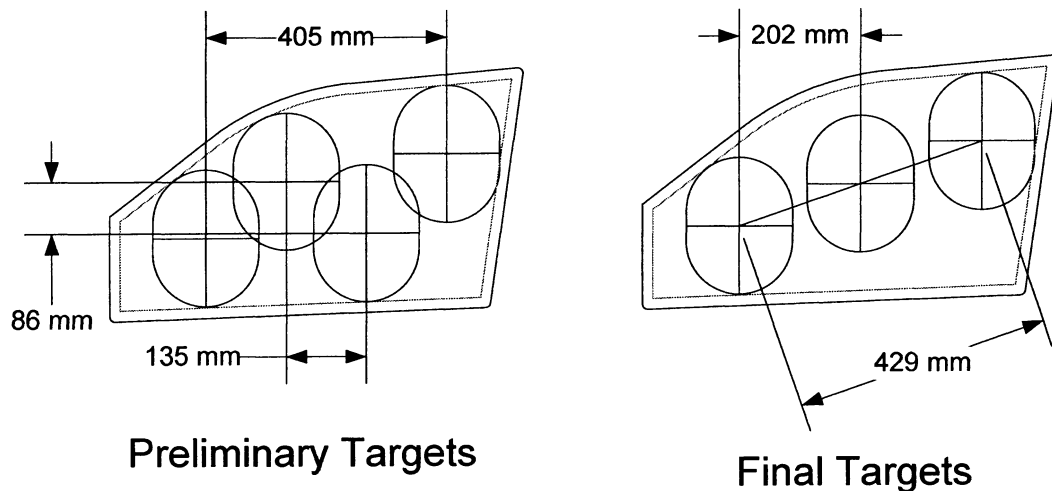

**Figure 12 – Adding a target between the remaining targets.**

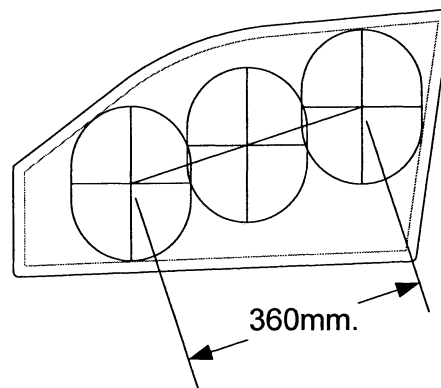

**Figure 13 - Smallest distance between primary targets for which a center target is added.**

BILLING CODE 4910-59-C

### Summary of Procedure Identifying Target Locations

In summary, there are three main parts to the test procedure that identifies the test target locations for each daylight opening. The three parts are summarized below.

#### Part 1

- Find the corners of the window opening, then locate the geometric center of the daylight opening. Separate the opening into four quadrants, *i.e.*, lower-front, lower-rear, upper-front and upper-rear. Eliminate the target in certain quadrants, leaving two “primary targets.”

- Measure the horizontal distance between the centers of the primary

targets. Divide that distance into thirds. Identify the two “secondary targets.”—For front windows, at the first  $\frac{1}{3}$ , place a target and move it vertically upward until contact is made with the offset line. At the second  $\frac{1}{3}$ , place a target and move it downward until contact is made with the offset line.—For rear windows, do the same, except that the first  $\frac{1}{3}$  target is moved downward, and the second  $\frac{1}{3}$  target is moved upward.

#### Part 2

- Evaluate whether some of the four targets should be eliminated because they excessively overlap. Determine whether target centers are closer than 135 mm and 170 mm in the horizontal and vertical directions, respectively.

#### Part 3

- If, after following the procedure given in part 2, there are only two targets remaining, determine the absolute distance between the centers of these targets. If this distance is at least 360 mm, locate a target so that the center of its outline bisects a line connecting the remaining targets.

#### *e. How Should the Window Glazing Be Positioned or Prepared in the Test To Represent Real-World Circumstances?*

We are proposing to allow windows to be in position (up and closed), but pre-broken. We are proposing to allow windows to be in position so as to not discourage the use of advanced glazing (laminated glazing) in vehicles, since our testing has shown that advanced

glazing may enhance the performance of current air bag curtain designs. Typically, advanced glazing has a multi-layer construction with three primary layers: a plastic laminate bonded between two pieces of glass. In the proposed test procedure, prior to running the headform impact test, we would undertake a procedure on all glazing that entails pre-breaking the glazing in a consistent fashion to simulate the breakage of glazing during a rollover. With advanced glazing, the procedure would likely result in the outside glass breaking without deforming the laminate. With tempered

(non-advanced) glazing, the procedure would likely shatter the glazing into fragments, so manufacturers would be given the option of: (a) Running the procedure and shattering the glazing; or (b) having the glazing removed from the daylight opening, or if the glazing completely retracts into the vehicle structure, completely retracting the glazing, and simply bypassing the glazing-breakage procedure.

1. Window Position and Condition

The agency is proposing to have the windows in position (up and closed) in the impact test because, for the target population of this rulemaking, the front

row window through which an occupant was ejected was closed or fixed prior to the crash 69 percent of the time. Nearly all of the closed or fixed front row ejection route windows (99 percent) were disintegrated after the crash. Table 21 shows these data for three seating rows. For many vehicles, the rear seat window is fixed. Our accident data show that the second and third row ejection route windows were closed or fixed about 94 and 100 percent of the time, respectively.<sup>78</sup> Combining all of the data, the ejection route windows were closed or fixed 72 percent of the time before the crash.

TABLE 21—PRE- AND POST-IMPACT WINDOW CONDITION FOR WINDOW THROUGH WHICH THE OCCUPANTS IN THE EJECTION MITIGATION TARGET POPULATION WERE EJECTED

Window location	Window condition				
	Pre-crash	Post-crash			
		Disintegrated (percent)	In Place (percent)	No Glazing (percent)	Total (percent)
Row 1	Closed or Fixed	68	1	0	69
	Open (Part. or Fully)	11	17	0	28
	No Glazing	0	0	3	3
	Subtotal	79	18	3	100
Row 2	Closed or Fixed	71	*23	0	94
	Open (Part. or Fully)	0	6	0	6
	No Glazing	0	0	0	0
	Subtotal	71	29	0	100
Row 3	Closed or Fixed	100	0	0	100
	Open (Part. or Fully)	0	0	0	0
	No Glazing	0	0	0	0
	Subtotal	100	0	0	100
All	Closed of Fixed	68	4	0	72
	Open (Part. & Fully)	10	16	0	26
	No Glazing	0	0	2	2
	Total	78	20	2	100

\*This result seems to suggest that 23 percent of the target population ejected from the second row went through a closed window that remained in place after the crash. This is a physical impossibility and represents ambiguity in NASS. These data are derived from an unweighted count of 18 NASS occupants of the approximately 1,200 occupants that make up the unweighted target population. The miscoding is likely a result of the fact that the NASS investigator has multiple side window ejection routes to properly code.

Table 22 shows the result of expanding the data set to include all vehicles exposed to a rollover crash, as opposed to just windows through which occupants were ejected. The restriction on the data is that an occupant needed to be seated next to the window opening. The data is separated into front row and rear rows, inclusive of the third

row. It is comprised of 2.9 million weighted data points. We note that only windows disintegrated from vehicle structural deformation have been tabulated.<sup>79</sup> This expanded data set shows a higher percentage (86 percent) of front windows are closed or fixed prior to a rollover than was the case for windows which were ejection routes. It

also shows that about half (47 percent (40 percent/86 percent)) of these closed or fixed front row windows were disintegrated after the crash. For the rear rows, the proportion of disintegrated windows, which were closed prior to the rollover, drops to 22 percent (22 percent/98 percent).

<sup>78</sup>The third row data is very limited. It is comprised of only 103 weighted ejections.

<sup>79</sup>Windows disintegrated due to occupant contact would add only about 0.5 percent to this data set.

TABLE 22—PRE- AND POST-IMPACT WINDOW CONDITION FOR VEHICLES EXPOSED TO A ROLLOVER WITH AN OCCUPANT ADJACENT TO THE WINDOW—1997 TO 2004 NASS CDS

Window location	Window condition			
	Pre-crash	Post-crash		
		Disintegrated (percent)	In place (percent)	Total (percent)
Front .....	Closed or Fixed .....	40	46	86
	Open (Part. or Fully) .....	3	11	14
	Subtotal .....	43	57	100
Rear .....	Closed or Fixed .....	22	76	98
	Open (Part. or Fully) .....	0	2	2
	Subtotal .....	23	77	100
All .....	Closed or Fixed .....	39	49	87
	Open (Part. & Fully) .....	3	10	13
	Total .....	41	59	100

### Request for Comments on Glazing Position and Condition

Although we believe that available data support a proposal allowing windows to be in place and pre-broken prior to testing, we recognize there are potential drawbacks to the proposal. On the issue of window position, the most obvious of these drawbacks is for those instances where manufacturers utilize advanced glazing in their design, when the window is partially or fully down the vehicle may have degraded occupant retention. This concern arises most frequently for first row windows, which are nearly always retractable. The implication of the data in Table 21 is that about 3 out of 10 occupants are ejected with the front window when it is partially or fully open prior to the crash. This becomes much less likely for the second and third rows.

The agency is contemplating alternatives to the approach of allowing windows to be in place and pre-broken. One option would be to test with all movable windows removed or rolled down, regardless of whether the window is laminated. Fixed laminated windows would continue to be kept in place, but pre-broken. This would assure that the ejection mitigation performance of vehicles with laminated windows is equal to those without laminated windows, when the windows happen to be rolled down. However, this would not provide an incentive to vehicle manufacturers to install advanced glazing in movable windows.

Another option would be to test the vehicle both with movable laminated windows down and with them up and pre-broken. The arithmetic or weighted average of the measurements could then

be used to determine compliance with the displacement limit. (One possible weighting would represent the probability of windows up versus windows down.) We are also considering placing some higher displacement limit on the window down test for these systems that use both advanced glazing and an ejection mitigation air bag curtain to provide protection. *E.g.*, if we were testing with the window down, we are considering permitting a displacement of more than 100 mm.

We request comments and ask for information relating to the following questions:

- The agency has proposed allowing windows with advanced laminated glazing to remain up, but pre-broken during impact testing. We are also considering testing with all movable windows down or removed, regardless of whether they are laminated. Finally, we discussed requiring testing with laminated windows both up and down. Please comment on the relative merits of these different options. Please comment specifically on the effect these options will have on overall benefits of the standard.

- The extent to which manufacturers will avail themselves of advanced glazing to supplement air bag curtains is unknown. We are aware that some manufacturers currently provide laminated glazing as a theft prevention and noise reduction measure in more expensive vehicles. We believe that incorporation of advanced glazing for ejection mitigation will be relatively expensive compared to the implementation of side curtain air bags. Our preliminary analysis shows that the proposed requirements would add about

\$33 per light vehicle at a total cost of \$568 million for the full curtain countermeasure. To what degree will manufacturers avail themselves of an advanced glazing option? What would be the costs associated with advanced glazing alone or in combination with side air bag curtains as opposed to the use of side air bag curtains alone?

- Our data analysis shows that for the target population of this proposal, about 30 percent of front windows will be rolled down prior to the crash. We are aware that vehicle manufacturers are researching and beginning to implement technology that senses an impending crash and roll the windows up. Should a windows-up ejection mitigation test option be restricted to only these vehicles?

- Advanced laminated glazing has considerably greater mass, particularly as compared to an air bag curtain. The inertial effects due to the mass of the advanced glazing and its retention by the vehicle structure are not accounted for in the proposed test procedure. To what extent might the advanced glazing mass degrade its real-world performance? Should NHTSA account for this in some way in our testing? If so, how?

### 2. Window Pre-Breaking Specification and Method

We are proposing a breaking specification and method that calls for punching holes in the glazing in a 50 mm horizontal and vertical matrix (“50 mm matrix”). A spring-loaded automatic center punch would be used to make the holes. The punch has approximately a 5 mm diameter before coming to a point. The first step in the process is to mark the surface of the

window glazing in a horizontal and vertical grid of points separated by 50 mm, with one point coincident with the geometric center of the daylight opening (see Figure 14). The initial target point of the punch would be the lowest and most forward mark made on the glazing. Holes would be punched in the glazing starting with the inside surface of the glazing, and starting with this initial lowest and most forward hole in the pattern. We would continue punching holes 50 mm apart, moving rearward on the vehicle. When the end of a row is reached, we would move to the most forward hole in the next higher row, 50

mm from the punched row. After completing the holes on the inside surface, we would repeat the process on the outside surface at the same impact points as the inside surface. These patterns are shown in Figure 14 below.

When punching a hole, we would place a 100 mm by 100 mm piece of plywood on the opposite side of the glazing as a reaction surface against the punch. The spring on the punch would be adjusted such that  $150 \text{ N} \pm 25 \text{ N}$  of force<sup>80</sup> would be required for activation. The force has been designed so as to not penetrate the inner laminated material. However, if a particular window were constructed

such that the inner laminated material is penetrated or damaged, the procedure would not be halted or invalidated; the headform impact test would be conducted at the conclusion of the glazing breakage procedure. If punching a hole causes the glazing to disintegrate, as would likely occur when testing tempered glazing, the procedure would be halted and the headform impact test would be immediately conducted. (In the latter situation, the vehicle manufacturer would have opted not to have removed or completely retracted the tempered glazing and thereby bypass the window breaking process.)

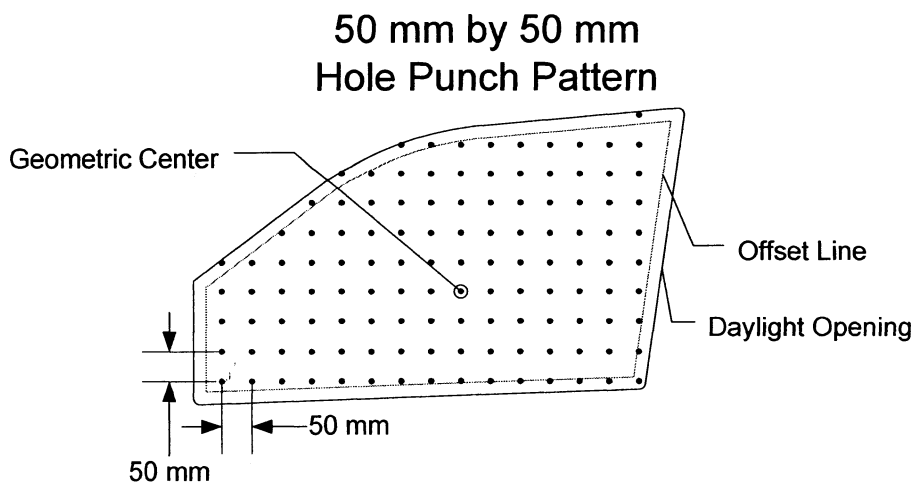

**Figure 14**

In developing the proposed glazing breaking specification and method, we considered and rejected a recommendation from an industry group called the Enhanced Protective Glass Automotive Association (EPGAA), which provided a test report entitled "Laminated Glass Pre-breakage Repeatability Testing," (see docket for this rulemaking). The EPGAA evaluated

whether different degrees of breakage affected laminated glazing strength. Four different degrees of breakage were tested and compared to glazing that had no breaks. The four were: 1 punched hole, 4 punched holes, 8 punched holes and completely pummeled with a ball-peen hammer. The 4-hole punch pattern was made by first locating the ejection headform contact point with the glazing

at each impact location for that window opening (see Figure 15). Each side of the glass was punched with a spring activated center punch tool at each contact location. The EPGAA recommended that NHTSA use the 4-hole punch pattern, but NHTSA has tentatively decided to propose the 50 mm matrix pattern rather than the 4-hole pattern, as explained below.

<sup>80</sup>This force level worked well for the samples of advanced glazing tested by the agency.



### Impactor Contact Point Hole Punch Pattern

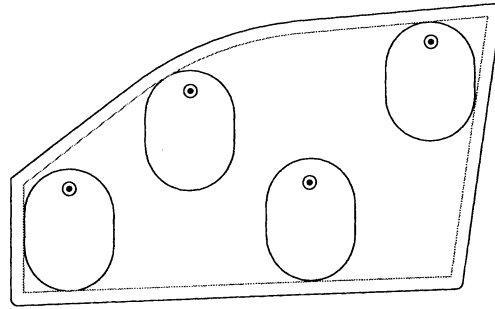

Figure 15

EPGAA’s tests evaluated the strength of the glazing by using a ball impact test prescribed in FMVSS No. 205 and the American National Standards Institute (ANSI) in “American National Standard, Safety Code for Safety Glazing Materials for Glazing Motor Vehicles Operating on Land Highways, ANSI Z26.1.” In the ball impact test, a 2.2 kg steel ball was dropped from 7.9 meters onto the glass, which was supported from underneath. At this height, the ball struck the glass at 45 km/h. A speed trap was used to measure the velocity of the ball after it passed through the glass. The reduction in speed was used to calculate the energy absorbed by the glass. This energy was converted to a mean breaking height through a potential energy conversion. EPGAA found that there was no statistical difference in the mean breaking height for the glazing broken under the various methods. Thus, the EPGAA concluded that the 4-hole pattern would be acceptable.

NHTSA reviewed EPGAA’s data but determined that the EPGAA test results might not correlate with the ejection mitigation impactor test. The proposed impactor test is much slower than the ANSI/SAE Z26.1 ball impact test and the proposed impactor is much larger and massive. In addition, for most vehicles, the impactor load would be distributed by the air bag curtain. Finally, the glass is mounted differently in a vehicle than on the test jig used in

the EPGAA study. Given all these differences, NHTSA performed follow-on testing to the EPGAA study, using the proposed 18 kg impactor with the laminated glazing pre-broken using the 4-hole pattern, as well as fully pummeled with a hammer. We also used the 50 mm matrix pattern to attempt to recreate the more fully broken pattern achieved by the fully-pummeled method in a more managed and objective manner.

In NHTSA’s follow-on testing, we found that the breaking method for the glazing resulted in very different breakage patterns (see Technical Analysis) and in different displacement results. Table 23 shows the limited test results to date. For all tests except the Durango at 16 km/h at position A3, the fully-pummeled glazing exhibited more impactor displacement than either hole pattern. There was a statistically significant difference ( $p = 0.024$ ) between the 4-hole pattern and the pummeled glazing. We have only one test using the 50 mm matrix pattern on a MY07 Jeep Commander. For this vehicle, there is a 7 mm reduction in displacement for the 50 mm matrix pattern and a 10 mm reduction for the 4-hole pattern over the pummeled glazing.

From the above data, we have tentatively concluded that the method of pre-breaking the laminated window has a discernable effect on the test

results. Generally, the methods that result in more breakage also result in less displacement reduction of the impactor, *i.e.*, more overall displacement in the proposed compliance test. Our decision for this NPRM is to propose a method that results in more breakage than less, to replicate more demanding scenarios involving breakage of the advanced glazing. However, the most demanding method (pummeled the glazing) was also the method that was the least controllable and the most potentially difficult to repeat from laboratory to laboratory. Accordingly, we have tentatively decided to adopt the 50 mm matrix hole punching method, since it appears to be more controllable and repeatable than pummeled the window with a hammer, and yet yields a very extensive breakage pattern. Comments are requested on the method of pre-breaking the glazing.

The agency is continuing its research into window pre-breaking methods. Specifically, we are looking into a variation of the 50 mm matrix hole punch method where the holes on either side of the glass are offset by 25 mm. Initial indications are that this variation exhibits the potentially positive attribute of lessening the chances of penetrating the inner membrane between the glass layers. Comments are requested on this issue.

TABLE 23—IMPACTOR DISPLACEMENT DATA FOR LAMINATED GLAZING PRE-BROKEN BY DIFFERENT METHODS

Test conditions			Displacement (mm) vs. glass condition					
Vehicle	Speed (km/h)	Target	4-holes		Pummeled		50 mm matrix	
05 Trailblazer .....	20	A2	62	.....	80	.....	.....	.....
05 Trailblazer .....	20	A3	96	98	107	110	.....	.....
06 Durango .....	20	A2	71	.....	101	.....	.....	.....
06 Durango .....	16	A3	145	.....	142	.....	.....	.....
07 Commander .....	16	A2	48	.....	58	.....	51	.....

### Request for Comments

Although testing by EPGAA showed no difference in the mean breaking strength for laminated windows regardless of the method used to pre-break them, ejection mitigation testing did show a significant difference between a 4-hole pattern and pummeling with a ball-peen hammer. The 50 mm matrix breaking method resulted in a very extensive fracture pattern of the window. The 4-hole pattern did not. Accordingly, we are proposing a 50 mm spacing breakage pattern through the use of a spring-loaded center punch with a  $5 \pm 2$  mm diameter prior to the tip, adjusted to an activation load of  $150 \pm 25$  N load.

We request comments on the following issues.

- The agency has proposed allowing windows with advanced laminated glazing to remain up, but pre-broken during impact testing. (As noted earlier, we are also considering different alternatives, including not having the windows up at all.) We have proposed a hole punch pattern with a 50 mm matrix spacing to break the window. Please comment on the appropriateness of the window breaking procedure. Specifically, is the window condition representative of what would be seen in the field as being caused by a crash prior to occupant ejection? Is it necessary to fracture the glazing more extensively than the proposed method? If so, what is the alternative method and its basis?

- Is the spring loaded automatic center punch sufficiently described by specifying an activation force of  $150 \pm 25$  N? Is it necessary to specify the impact force generated when the spring tension is released? If so, what procedure should be used to determine the impact force? Is it sufficient to specify that the punch diameter be  $5 \pm 2$  mm prior to the tip? Does there need to be a specification regarding the sharpness of the tip? If so, what should the specification account for?

#### f. Test Procedure Tolerances

The proposed regulatory text for this ejection mitigation standard has tolerances on various test parameters of the proposed test procedure. For example, the proposed text specifies that the target outline must be aligned within  $\pm 1$  degree of the vehicle longitudinal plane when determining the proper target location. Tolerances were selected such that they would not affect the test results, yet not be so small as to be unusable. In some instances, we have based tolerances on those of other FMVSSs because those tolerances have

been practicable and useful. For example, the tolerance on the impactor alignment with the vehicle lateral axis is based on a similar linear impactor tolerance in S5.2.5(c) of FMVSS No. 202a. Tolerance selection has been based on test experience and engineering judgment. Comments are requested on whether the tolerances assure an objective, repeatable and practical test procedure.

#### g. Impactor Test Device Characteristics

There are many possible ways of delivering the impactor to the target location on the ejection mitigation countermeasure. As previously discussed, the impactor used in agency research propels the shaft component of the impactor with a pneumatic piston. The shaft slides along a plastic (polyethylene) bearing (sleeve). This section explores the need to specify characteristics of the impactor to maximize the objectivity of the standard.

We have tentatively determined that certain characteristics of the impactor should be specified to enhance the repeatability of the test, *i.e.*, to increase the likelihood that the headform will be delivered to the countermeasure and interact with it in a repeatable manner. A specification we are considering in proposed S7.2 would limit the amount of energy the impactor may lose due to friction. All guided impactor designs will have some degree of velocity loss due to friction on the impactor shaft. To enhance the objectivity of the test procedure, we propose to specify that the ejection impactor must not lose more than 10 and 15 percent of the 24 and 16 km/h impact velocity, respectively, in 300 mm of unobstructed travel. The agency performed five speed trials with the ejection mitigation test device used for the agency's research.<sup>81</sup> We found that the average and standard deviation for the percentage velocity reduction was  $8.2 \pm 1.9$  percent and  $16.2 \pm 4.4$  percent, for the 24 and 16 km/h impact speeds, respectively; our research test device lost a higher percentage of energy at the lower impact speed. Comments are requested on the need for and merits of these proposed values. Should there be an upper and lower limit on each value?

Another specification under consideration relates to assuring that the projection of the impactor would not be unduly set off target when it impacts a countermeasure. The ejection mitigation

<sup>81</sup> This research test device has not been optimized for compliance test purposes. Thus, we believe that tighter tolerance can be attained with an optimized design.

countermeasure could impart off-axis loading on the impactor, *i.e.*, the loading may not just be in the direction of the impactor shaft. This off-axis loading may affect the impactor in several ways. If the impactor shaft and support mechanism is overly flexible, off-axis loading may allow the impactor headform to deviate unduly from its intended target. We have seen this in our testing when the headform strikes near the bottom of the curtain. The curtain makes contact predominately on the upper portion of the headform, which can cause a downward loading on the impactor and a change in its intended path. This off-axis loading on the headform may also allow the shaft bearing to be exposed to additional loading and potentially increase the friction on the shaft.

We are thus proposing specifications in S7.1.2 that would reduce the effects of off-axis loading on the impactor device. First, we are proposing to limit bending of the device in a static test. In the test, the impactor would be extended 300 mm past the position where the test impact velocity (24 or 16 km/h) is achieved. At that position, a 27 kg mass would be attached to the back of the headform. We would require that the headform's maximum vertical deflection, with the mass, must not exceed 20 mm. Second, we are proposing that, with this 27 kg mass attached, the average and standard deviation required to push the impactor over a 200 mm distance at a velocity of  $50 (\pm 13)$  mm per second must not exceed 570 N and 30 N, respectively.

Finally, in proposed S7.3 we set forth an additional way to assure the impact test device delivers the headform to the required target location on the side window opening. Briefly stated, this assessment would determine the accuracy of the headform in hitting a determined zone, similar to a pitcher in the game of baseball finding the strike zone. The assessment would be conducted by establishing a zone within which we would require the impactor to deliver the headform at test speed. The following describes one objective method of determining the "strike zone," to use the baseball analogy. Comments are requested on whether other methods of determining the zone would be preferable and what those methods should be.

As shown in Figure 16, a zone could be established by first determining the "ejection impactor targeting point," the intersection of the x- and y-axes on the outer surface of the headform. Next, the location of first contact between the impactor and the ejection mitigation countermeasure (*e.g.*, ejection mitigation

air bag curtain) would be determined, based on the location of the target outlines using the methodology in the compliance test specified for identifying the target outlines. A 100 mm wide zone would be determined by defining two vertical longitudinal planes that are 50 mm on either side of the expected location of contact by the impactor with the countermeasure. These longitudinal planes define a portion of the strike zone. The other portion of the zone would be defined by locating the axis normal to and passing through the target outline center. As the impactor targeting point passes at test speed through the 100 mm wide zone (as it passes “over

the plate,” using the baseball analogy), it must stay within  $\pm 10$  mm of the axis passing through the center of the target outline center (continuing the analogy, it must stay within the vertical zone bounded by the batter’s knees and chest). This assessment would not be conducted with an ejection mitigation air bag curtain deployed, as the deployed curtain could obstruct accurate measurement of the impactor location and the effect of air bag interaction is assessed by the specification previously discussed.

Comments are requested on these proposals. We are considering making this assessment of the impactor to

assure that the impactor used in the compliance test has the specified characteristics adopted by the standard. If the impactor was able to meet the specifications during the assessment, it would be assumed that the impactor has the characteristics enabling it to meet the specifications and that it had those characteristics during the compliance test of the countermeasure. Are there any other or different characteristics of the ejection impactor that should be specifically defined?

BILLING CODE 4910-59-P

### Targeting Accuracy

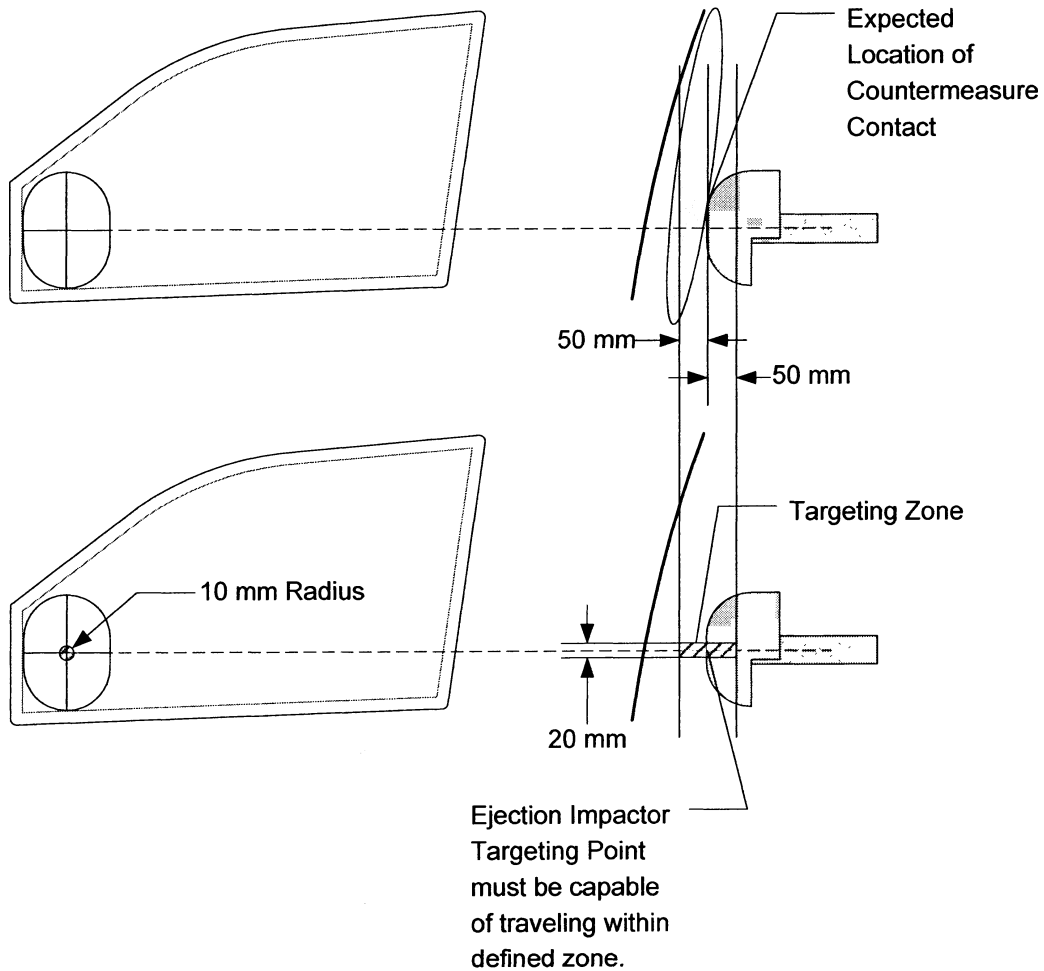

Figure 16

#### *h. Readiness Indicator*

NHTSA is proposing a requirement for a readiness monitoring system with a readiness indicator for ejection mitigation systems that deploy in a rollover, such as that required for frontal air bags in S4.5.2 of FMVSS No. 208. The indicator would monitor its own readiness and would have to have a telltale clearly visible from the driver's designated seating position. We would permit vehicle manufacturers to use the same frontal air bag readiness indicator telltale currently used to meet S4.5.2 of FMVSS No. 208. We also propose that manufacturer would have to include in the vehicle owner's manual, or other written material accompanying the vehicle, a list of the elements of the system being monitored by the indicator, a discussion of the purpose and location of the telltale and instructions to the consumer on the steps to take if the telltale were illuminated. These proposals are intended to enhance the longevity and dependability of the ejection mitigation system over the life of the vehicle.

### **VI. Other Considered Performance Aspects of an Ejection Mitigation Standard**

#### *a. Rollover Sensor*

##### 1. Introduction

NHTSA has tentatively decided that the regulatory text for this NPRM will not specifically require a rollover sensor or specify attributes that the sensor must meet. As explained earlier in this preamble, deployable ejection mitigation countermeasures (ejection mitigation air bag curtains) are now being designed, developed, and implemented by industry and, SCI data suggest, are deploying satisfactorily in the field. To optimize the performance of ejection mitigation countermeasures at these early stages of development, we have decided to proceed with an ejection mitigation rulemaking absent a protocol for testing rollover sensors. Underlying our approach is that, even without an explicit requirement to provide a rollover sensor, manufacturers will provide sensor(s) with their ejection mitigation curtains. We have accounted for the cost of rollover sensors in our cost/benefit analysis for this rulemaking.

Our assumption that manufacturers will provide rollover sensors is based on several factors. First, as noted above, our SCI data for lateral rollovers for vehicles currently in the field with side curtain air bags intended for ejection mitigation show these systems have deployed in rollover crashes. These data show that

the installation of rollover sensors is practicable and that the sensors are working in the field. Second, this NPRM would require information in the owner's manual or other written material accompanying the vehicle to describe the ejection mitigation countermeasure that deploys in the event of a rollover if the deployable countermeasure is provided. With customer expectations at stake, there is virtually no incentive for manufacturers to provide an ejection mitigation side curtain designed to meet this NPRM without providing the sensor to deploy it in a rollover crash. In addition, manufacturers would be required to provide written information to NHTSA, upon the agency's request, explaining the basic operational characteristics of their rollover sensor system. Finally, we would deploy the ejection mitigation side curtain in the compliance test only if the owner's manual or other written material accompanying the vehicle informs the owner that the vehicle is equipped with an ejection mitigation countermeasure that deploys in the event of a rollover. If the information is not present, we would perform the headform test without deploying the ejection mitigation side curtain. An example of this situation might be a vehicle that has a side curtain primarily for side impact protection, but that uses advanced glazing to meet the ejection mitigation requirements. In this case a rollover sensor system would not be necessary. Thus, the written information provided would not indicate that there is a deployable countermeasure and the agency would not deploy the side curtain when testing this vehicle.

The agency acknowledges that the presence of a rollover sensor does not guarantee optimal performance of the sensor in the field. However, as noted earlier in this preamble and discussed further below, we are concerned as to whether specifying performance features for the sensor could satisfactorily capture the myriad of rollovers occurring in the real-world.<sup>82</sup> In addition, vehicle rollover crash attributes and rollover sensing needs could change as ESC and other changes are incorporated into vehicles. Rather than specify performance requirements for the sensor that might address certain types of rollover crashes and exclude others that should be addressed, this NPRM provides manufacturers maximum design flexibility in developing sensors that can achieve optimum performance in rollover

crashes likely to be encountered in the real world.

##### 2. Alternative Approaches

The agency considered alternative approaches on whether requirements for a rollover sensor should be specified at this time. These are discussed below and in the Technical Analysis for this NPRM.

One option was to propose that the rollover sensors be provided as a piece of equipment and define such a piece of equipment (Equipment Definition Option). The Equipment Definition Option involves simply having the FMVSS define the item of equipment (the rollover sensor) and having the FMVSS require the installation of the item of equipment. This option would assure a rollover sensor is present in the vehicle. However, it has the limitation of having to definitively specify the item of equipment it would be requiring, which might necessitate adopting and applying an overly restricted view of what a deployable rollover is and perhaps what it is not. For example, we can contemplate rollovers that have such an extremely slow roll rate when it would not be necessary or desirable for the countermeasure to deploy. That being the case, a reasonable definition of a rollover sensor might include a roll rate specification as a function of roll angle. Developing such a definition requires vehicle roll angle versus rate data, which are not readily available to NHTSA. Another potential drawback of this option is that without a test or tests to assess compliance with the definition, enforcement of the requirement could be restricted. An approach for a compliance test could be for NHTSA to remove the sensor from the vehicle and subject the sensor to a performance test to assess whether a specified performance requirement is achieved, but the agency has limited information at this time on which to develop performance parameters or a compliance test.

A second considered approach was to specify a test(s) that would assure the presence of a rollover sensor on the vehicle (Presence Test Option). A rollover test would be performed and the countermeasure would or would not deploy. One option was to propose a test, with which both the agency and industry have experience, which is certain to deploy the countermeasure if a sensor were present and functioning. One such test would be the FMVSS No. 208 dolly test. However, the use of the FMVSS No. 208 dolly test as a rollover sensor test might be a somewhat incomplete solution due to the variation in real world rollover crashes. Even

<sup>82</sup> Several types of rollover crashes are described by Viano and Parenteau, "Rollover Crash Sensing and Safety Overview," SAE 2004-01-0342, *supra*.

with an indefinite development time period, there would be difficulties in defining and developing any test(s), and in determining the real-world relevance of the test procedure(s). The agency does not have sufficient knowledge of any repeatable rollover test that merits selection as the test that replicates the breadth of real-world rollovers addressed by this rulemaking. Developing tests that assure good sensor performance would require additional research, which would delay the proposal and adoption of this FMVSS.

The third approach we considered was a "phase-plane zone" option suggested by the Automotive Occupant Restraints Council (AORC).<sup>83</sup> This option basically requires the rollover sensor to deploy a countermeasure if, prior to rolling more than 90 degrees about the lateral axis, the vehicle roll angle versus rate curve exceeds a threshold. The agency has no data to independently judge the AORC deployment threshold against ideal field performance. Therefore, we cannot assure that it represents the minimally acceptable performance. This option only considers roll angle and roll rate as sensor inputs, while AORC members indicated that many systems use other sensor inputs and that future sensors may be integrated into and/or use information from ESC systems. As discussed in the Technical Analysis for this NPRM, we would need some time to develop the potential test parameters and apparatuses for this approach.

NHTSA requests comments on the following issues:

- The agency has not included any regulatory requirements for sensor(s) that will deploy ejection mitigation countermeasures during a rollover. Comments are requested on the alternative approaches considered by the agency. Are there other alternatives that the agency has not considered? Are there particular performance attributes of a sensor system and algorithm that this FMVSS should require of all vehicles? Are there any particular sensor system performance tests that should be conducted? How should the sensor system be tested, e.g., a test of the system or equipment separate from the vehicle, a test of the complete vehicle in a dynamic test, etc.? Please provide field studies to support your arguments.

- Please comment on the AORC proposal for minimum sensor performance and how the agency could test for such performance, including specifics about test devices. Please discuss the appropriateness of

specifying the test parameters and leaving the specific apparatus undefined.

#### *b. Quasi-static Loading in a Compliance Test*

Films of occupant kinematics in vehicle rollover testing and in DRF testing indicate that ejection mitigation countermeasures can be exposed to quasi-static loading during a rollover, in addition to short-duration impacts that the headform test replicates. Quasi-static loading can occur when an occupant contacts the countermeasure and loads it throughout or nearly throughout an entire rollover event. Once an occupant contacts the ejection countermeasure, the occupant could impose a centrifugal force on the countermeasure. That force depends upon the rotational velocity, the radius from center of rotation to contact point on the countermeasure, and the portion of occupant mass loading the countermeasure.

The value for each of these variables will be rollover and vehicle specific. Assuming a roll rate of 250 deg./s (4.4 rad./s), a radius of 1.3 m and a mass equal to half the mass of a 50th percentile adult male (37 kg), the force is equal to 931 N (209 lb).

- The agency has not studied how ejection countermeasures perform when exposed to quasi-static loading, or whether the impact test alone would adequately facilitate the manufacture of ejection countermeasures that perform well when subjected to quasi-static loading in a rollover. NHTSA requests comments on the need for an additional test(s) that would impose quasi-static loading on the ejection countermeasure. What would be an appropriate load value and loading period? What would be an appropriate quasi-static test procedure?

#### **VII. To Which Vehicles Would the Proposed Standard Apply?**

We propose that this standard would apply to passenger cars, multipurpose passenger vehicles, trucks and buses with a gross vehicle weight rating (GVWR) of 4,536 kg (10,000 lb) or less. Those are the vehicle classes to which the FMVSS No. 214 pole test applies. Comments are requested on whether the standard should exclude the vehicle types listed below, and whether other vehicle types not listed below should also be excluded.

*Convertibles.* NHTSA has tentatively determined that convertibles should not be excluded from the applicability of the standard because we believe there is potential benefit and because it is feasible to build countermeasures into

this type of vehicle. First, approximately 17% of the target population fatalities are in side impacts or side impacts followed by a rollover. Even absent any roof structure, we believe that side curtain air bags and/or advanced glazing may be effective in reducing ejections in this side impact population and perhaps, to a lesser degree, in the side impact followed by a rollover population. We realize that occupants of convertibles in other rollover crashes of two or more quarter-turns are extremely vulnerable due to the lack of roof structure. This is particularly true if the convertible top is down or hardtop is removed. However, survival space may exist, particularly for convertibles with roll bars behind the seats such as the Mini Cooper and Porsche Boxster. The version in the Mini Cooper is recessed behind the rear seats and deploys in a rollover. Although we have no firm data on the percentage of convertibles driven with the top up, if they are and there is a roll bar type structure, ejection mitigation countermeasures may be effective.

On the issue of feasibility, although these vehicles do not have a permanent roof structure in which to house a roof-mounted ejection mitigation curtain, Porsche has indicated to NHTSA that it is developing a door-mounted curtain that would deploy upward toward the vehicle roof in a rollover.<sup>84</sup> Comments are requested on the feasibility of installing door-mounted ejection mitigation curtains in convertibles on a widespread basis, and if feasible, the costs and benefits associated with door-mounted ejection mitigation curtains. Please comment on the practicability of certifying convertibles to the proposed performance test with door-mounted ejection mitigation curtains and/or advanced glazing. Could advanced glazing alone be a sufficient ejection mitigation countermeasure in convertibles? If it is not practicable to meet the proposed requirements with any countermeasures, please indicate how the proposed performance requirement and test procedure could be adjusted to be more appropriate for convertibles, such as by changes to the displacement limit, impact velocity, target locations, etc.

*Vehicles that have had the original roof modified.* If a vehicle were altered or modified such that the original roof were replaced, raised or otherwise modified, the original ejection mitigation window curtain that was mounted in the header above the door would be affected by such modification. NHTSA proposes excluding vehicles

<sup>83</sup> July 12, 2006 meeting between NHTSA and AORC (NHTSA-2006-26467-11).

<sup>84</sup> NHTSA-2006-26467-10.

with modified roofs from the standard, and adopting FMVSS No. 214's definition of a "modified roof." That standard defines "modified roof" as "the replacement roof on a motor vehicle whose original roof has been removed, in part or in total." However, should vehicles with door-mounted upward-deploying side curtain air bags installed as original equipments be excluded from the ejection mitigation standard if the vehicle's roof is later modified? There might not be a need to exclude such vehicles from the ejection mitigation standard if the door-mounted ejection mitigation countermeasure would not be significantly affected by the modification to the vehicle's roof.

*Vehicles with a lowered floor.* NHTSA does not think there is a need to exclude from the standard vehicles that have had their floors lowered by a final-stage manufacturer or alterer. It does not appear that the ejection mitigation countermeasure would be significantly affected by the modification, or that it would be overly difficult for the manufacturer to certify the compliance of the vehicle. Comments are requested on this issue.

*Vehicles that have no doors, or exclusively have doors that are designed to be easily attached or removed so that the vehicle can be operated without doors.* Comments are requested on whether these vehicles are still being manufactured in the U.S. Assuming the vehicles are being manufactured, NHTSA proposes excluding the vehicles on practicability grounds. Comments are requested on this issue.

*Walk-in vans.* We propose excluding these vehicles on practicability grounds.

*Police vehicles with security partitions.* Considering that law enforcement vehicles are more likely to be involved in risky driving operations than other passenger vehicles, NHTSA would prefer that the vehicles provide ejection mitigation countermeasures. However, security partitions (*e.g.*, prisoner partitions) are necessary for the safety and security of the law enforcement officers, and they must be flush against the sides of the vehicle to prevent a prisoner's hand or article from intruding into the officer's compartment. We would like information as to whether police vehicles with security partitions should be excluded from the standard. Comments are requested on whether innovative partition designs exist that would permit the side curtain air bag to be deployed effectively without interference from a security partition. Alternatively, is it feasible to incorporate separate curtains for the front and rear passenger compartments?

Is it feasible to incorporate a window curtain for the front compartment and advanced glazing for the rear compartment? Is it feasible to incorporate air bag curtains that deploy upwards (*e.g.*, as in the Volvo C70?) In addition, would advanced glazing alone be sufficient in these vehicles to meet the standard? The agency has tentatively decided not to exclude vehicles with partitions generally, because it appears that a partition other than a security (prisoner) partition could be made compatible with a window air bag curtain by allowing a space between the daylight opening and the partition edge. Comments are requested on these tentative determinations.

#### VIII. The Proposed Lead Time and Phase-In Schedules

Motor vehicle manufacturers will need lead time to develop and install ejection mitigation countermeasures and rollover sensor algorithms. Although inflatable side curtain air bags are being developed in new vehicles to meet the September 11, 2007 final rule (as amended June 9, 2008) incorporating a dynamic pole test in FMVSS No. 214, to meet the requirements proposed today these side curtains will have to be made larger to cover more of the window opening, will have to be made more robust to remain inflated longer, and will have to be considerably enhanced (by tethering and other means) to retain vehicle occupants within the vehicle. Moreover, rollover sensor algorithms will be needed to deploy the ejection mitigation countermeasures in rollover crashes, to augment the sensors needed to deploy the side curtains in side impacts.<sup>85</sup> Our tests of vehicles to the proposed ejection mitigation requirements found that vehicle manufacturers are at different stages with respect to designing inflatable ejection mitigation side curtains that meet the proposed requirements. Vehicle manufacturers also face unique manufacturing constraints and challenges, *e.g.*, each face differences in the technological advances incorporated in their current air bag systems, differences in engineering resources, and differences in the numbers and type of vehicles for which ejection mitigation systems will need to be incorporated. NHTSA believes that these differing

<sup>85</sup> The FMVSS No. 214 final rule/response to petitions for reconsideration acknowledged that current side air bag sensors will have to be developed further to sense when it would be appropriate to deploy in a crash situation involving impacts up to 32 km/h (20 mph). NHTSA provided manufacturers until September 1, 2014 to develop these sensors. 73 FR 32473, June 9, 2008, Docket No. NHTSA-2008-0104.

situations can best be accommodated by phasing in the ejection mitigation requirements proposed today over a period of four years, and by allowing the use of advance credits.

We also believe that the phase-in of the ejection mitigation requirements should start after the date most vehicles will be certified as meeting the FMVSS No. 214 side impact pole test requirements.<sup>86</sup> This is in recognition of the potential for a side curtain system to meet both FMVSS No. 214 and the ejection mitigation requirements and that meeting both sets of requirements will place demands on manufacturers and air bag system suppliers to develop a "new generation" of side air bag curtains and sensors beyond those installed to meet the FMVSS No. 214 test requirements. Taking into account all available information, including but not limited to the technologies that could be used to meet the proposed testing requirements, the SAFETEA-LU provision that a final rule be issued by October 1, 2009, and the relatively low percentage of the fleet that has ejection mitigation countermeasures capable of meeting the proposed requirements, the agency is proposing to phase-in the new ejection mitigation requirements starting the first September 1 three years from the date of publication of a final rule. Assuming that a final rule would be issued in January 2011, NHTSA proposes that the phase-in would be implemented in accordance with the following schedule:

- 20 percent of each manufacturer's vehicles manufactured during the first production year beginning three years after publication of a final rule (for illustration purposes, that effective date would be September 1, 2014);
- 40 percent of each manufacturer's vehicles manufactured during the production year beginning, for illustration purposes, September 1, 2015;
- 75 percent of vehicles manufactured during the production year beginning, for illustration, September 1, 2016;

<sup>86</sup> The FMVSS No. 214 rule will be phased in and will apply to 80 percent of vehicles with a GVWR of 8,500 pounds or less manufactured on or after September 1, 2013. Advance credits may be used. All vehicles with a GVWR of 8,500 lb or less (except for altered and multistage vehicles and vehicles produced by limited line and small volume manufacturers) manufactured on or after September 1, 2014 must meet the upgraded FMVSS No. 214 requirements without use of advanced credits. All vehicles with GVWRs 8,500 to 10,000 lb (except for altered and multistage vehicles) manufactured on or after September 1, 2015 must meet the upgraded FMVSS No. 214 pole test requirements. All altered and multistage vehicles manufactured on or after September 1, 2016 must meet the upgraded FMVSS No. 214 requirements.

- And all vehicles (without use of advanced credits) manufactured on or after, for illustration, September 1, 2017.

NHTSA believes that the proposed phase-in would best address a number of issues. It would allow manufacturers to focus their resources in an efficient manner. Data obtained from the agency's 2008 model year New Car Assessment Program indicate that approximately 40 percent of 2008 model year vehicles are available with side air bags that are designed to deploy in a rollover and stay inflated for a duration longer than that needed to provide protection in a side impact not involving a rollover. However, this does not mean that these vehicles would be capable of complying with this NPRM. For example, the air bag curtain may not have sufficient window coverage or stay inflated long enough to meet the proposed requirements. Rather, these ejection mitigation systems are designed to the manufacturers' internal design criteria.

The agency believes that it would not be possible for manufacturers that produce large numbers of models of passenger cars and LTVs to simultaneously design and install ejection mitigation air bags meeting the proposed requirements in all of their vehicles at once. Manufacturers have limited engineering resources, and will have been using their resources to improve the performance of LTVs and passenger cars in the dynamic pole test and the moving deformable barrier vehicle-to-vehicle crash test of FMVSS No. 214. NHTSA seeks to provide vehicle manufacturers sufficient opportunity to adopt the best designs possible as quickly as possible. The agency tentatively concludes that a 4-year phase-in beginning three full years after publication of a final rule will provide the lead time needed while achieving the life-saving benefits of the final rule in as expeditious a manner as possible.

NHTSA further believes that the proposed phase-in would not be incompatible with the agency's efforts to upgrade FMVSS No. 216, "Roof crush resistance." The roof strength upgrade will mainly require structural redesigns in the areas of the A- and B-pillars, side and front header, and roof cross beams, particularly for heavier vehicles that were not previously subject to the standard. Potential vehicle modifications could include the incorporation of higher strength or higher gauge steel, adding supporting materials in the pillars, and/or reinforcing the roof-pillar joints. NHTSA believes that any structural changes needed in response to the new

roof crush resistance requirements will have an inconsequential impact on the ability to implement ejection mitigation countermeasures, such as rollover curtain air bags. Possible ancillary changes could include the need to accommodate larger air bag packaging and new curtain attachment points. Nonetheless, the agency is considering overlapping the phase-ins of both the roof crush resistance and ejection mitigation upgrades to afford vehicle manufacturers the opportunity to make needed modifications for compliance with both requirements at one time. Ultimately, the improved roof strength provided by FMVSS No. 216, in combination with the ejection mitigation countermeasures, will provide comprehensive protection for vehicle occupants involved in rollover crashes.

We also propose to include provisions under which manufacturers can earn credits towards meeting the applicable phase-in percentages if they meet the new ejection mitigation requirements ahead of schedule. In addition, as we have done with other standards, we are proposing a separate alternative to address the special problems faced by limited line and multistage manufacturers and alters in complying with phase-ins. A phase-in generally permits vehicle manufacturers flexibility with respect to which vehicles they choose to initially redesign to comply with new requirements. However, if a manufacturer produces a very limited number of lines, a phase-in would not provide such flexibility. NHTSA is accordingly proposing to permit "limited line" manufacturers that produce three or fewer carlines the option of achieving full compliance when the phase-in is completed. Flexibility would be allowed for vehicles manufactured in two or more stages and altered vehicles from the phase-in requirements. These vehicles would not be required to meet the phase-in schedule and would not have to achieve full compliance until one year after the phase-in is completed. Also, as with previous phase-ins, NHTSA is proposing reporting requirements to accompany the phase-in.

### IX. The Estimated Benefits and Costs of This Rulemaking

We are placing in the docket a Preliminary Regulatory Impact Analysis (PRIA) to accompany this NPRM.<sup>87</sup> The

<sup>87</sup> The PRIA may be obtained by contacting the docket at the address or telephone number provided at the beginning of this document.

PRIA analyzes the potential impacts of the proposed ejection mitigation requirements. A summary of the PRIA follows. Comments are requested on the analyses.<sup>88</sup>

The agency believes that curtain air bags will be used to pass the proposed ejection mitigation test. We believe that most manufacturers will have to widen the side air bag curtains that they are providing to meet FMVSS No. 214's pole test requirements, or replace combination (combo) seat-mounted side air bags with a curtain to pass the impactor test of this NPRM. We assume that vehicle manufacturers would install a single-window curtain for each side of the vehicle, and that these window curtains would provide protection for both front and rear seat occupants.

We primarily examined two different types of countermeasures that are designed to meet the proposed headform requirements. One approach covers the opening with a wider curtain air bag (called "full curtain" in the PRIA). However, we believe that even if the window is completely covered with a curtain air bag, some partial ejections could occur through a potential gap along the bottom of the air bag between the air bag and vehicle's window sill. The second countermeasure entails the installation of laminated glazing in the front window openings to prevent ejections through test point A1 and the lower gap (called "partial curtain plus laminated glazing" in the PRIA). In addition, we also examined how manufacturers would design an ejection mitigation system if we change the test requirements in one of two ways that may allow different countermeasures to comply with the standard. First, we analyzed the effect of reducing the impact speed for the 1.5 second delay test from 24 km/h to 20 km/h for the front lower corner (called "A1 full curtain" in the PRIA).<sup>89</sup> Next we

<sup>88</sup> The analyses were based on information voluntarily submitted by manufacturers at the end of 2006. Since that time, various manufacturers have reported that product plans pertaining to other rulemakings have changed due to changed economic circumstances. Comments are requested on the estimates provided in this section and in the PRIA.

<sup>89</sup> Notwithstanding the examination of these changes to the test requirements, the goal remains coverage of the whole window opening. As part of the rulemaking effort, the agency tested a prototype curtain ejection mitigation system developed by TRW in a dynamic rollover fixture (DRF). The test results showed that in a near worst case ejection condition, an unrestrained small child could be ejected through a small window opening (target position A1) when the area is not fully covered, even when initially aimed at another part of the window (target position A2). For additional discussion, see a report titled "NHTSA's Crashworthiness Rollover Research Program,"

analyzed the effect of reducing the number of target points to one, for both the 24 km/h and 16 km/h impact tests.

*Benefits.* The agency first identified the baseline target population and then estimated the fatality or injury reduction rate. The target population was defined as partially and completely ejected occupants in rollovers and certain side crashes. The agency's annualized injury data from 1997 to 2005 NASS CDS and fatality counts adjusted to 2005 FARS levels show that there are 6,174 fatalities and 5,271 MAIS 3+ non-fatal injuries for occupants ejected through side windows. We excluded from the estimate of this ejection mitigation rulemaking 649 fatalities and 243 MAIS 3+ non-fatal injuries already accounted for in the FMVSS No. 214 pole test rulemaking (September 11, 2007; 72 FR 51907). The most significant adjustment to the target population was for assumed full compliance with the Electronic Stability Control (ESC) final rule (April 6, 2007; 72 FR 17236), which reduced the target population by 3003 fatalities and 2,854 MAIS 3+ non-fatal injuries. Finally, after adjusting for anticipated compliance with today's proposed rule, we estimate that this NPRM being met

by a full curtain would save 402 lives and prevent 310 serious injuries, annually.<sup>90</sup> For the estimated benefits, we assumed that the belt use rate observed in 2005 remains unchanged. The majority of the benefits are for unbelted occupants but the analysis shows that 13 percent of the benefits would be from belted occupants: 10 percent from rollovers and about 3 percent from side crashes considered.

*Costs.* Potential compliance costs for the linear headform test vary considerably and are dependent upon the types of the FMVSS No. 214 head/side air bags that will be installed by vehicle manufacturers to comply with the oblique pole test requirements. For vehicles with two rows of seats to be covered with a curtain air bag, we estimate an ejection mitigation system (consisting of 2 window curtains, 2 thorax air bags for the front seat occupants only, 2 side impact sensors and 1 rollover sensor) would cost about \$299.44, when compared to a vehicle with no side air bags. This is \$49.97 more than a vehicle with a side air bag system designed to meet the FMVSS No. 214 pole tests. The MY 2011 sales show that 25% of light vehicles will have a

third row seat. When the first through 3rd row are covered with a curtain air bag, we estimated the cost per vehicle will increase by \$61.92, when compared to a vehicle equipped with a FMVSS No. 214-curtain system.

The manufacturers' plans for MY 2011 head air bag sales show that about 1%, 44% and 55% of vehicles would be equipped with combination air bags, curtain air bags without rollover sensors and with rollover sensors, respectively.<sup>91</sup> Thus, manufacturers are planning to provide 55% of the MY 2011 vehicles with an expensive part of the cost of meeting the ejection mitigation test, the rollover sensor, which is estimated to cost \$38.02. Given that 25% of light trucks have 3 rows of seats, we estimate the average cost per vehicle would increase by \$54 if there were no voluntary compliance by manufacturers for MY 2011. Manufacturers' plans for MY 2011 indicate at least \$20 per vehicle of costs toward this proposal. Thus, compared to the manufacturers' plans, this ejection mitigation proposal would add about \$34 per light vehicle, at a total cost of \$583 million for the full curtain countermeasure.

TABLE 24—TOTAL AND AVERAGE VEHICLE COSTS \*  
[\$2007]

Costs	Ejection mitigation system	Weighted MY 2011 manufacturers' plans	Incremental costs
Per Vehicle Costs .....	\$54 .....	\$20 .....	\$34.
Total Costs (17 million vehicles) .....	\$920 million .....	\$337 million .....	\$583 million.

\* The system costs are based on vehicles that are equipped with the FMVSS No. 214-curtain system. According to vehicle manufacturers' projections made in 2006, 98.7% of MY 2011 vehicles will be equipped with curtain bags and 55% of vehicles with curtain bags will be equipped with a roll sensor.

*Cost per Equivalent Life Saved and Net Benefits.* The PRIA estimated the net costs per equivalent life saved. For the full curtain countermeasure, the low end of the range is \$1.6 million per equivalent life saved, using a 3 percent discount rate. The high end of the range is \$2.0 million per equivalent life saved, using a 7 percent discount rate.

Net benefit analysis differs from cost effectiveness analysis in that it requires

that benefits be assigned a monetary value, and that this value is compared to the monetary value of costs to derive a net benefit. When we assume that the percentage of MY 2011 air bag sales remain unchanged (*i.e.*, 1%, 44% and 55% of vehicles would be equipped with combination air bags, curtain air bags without rollover sensor and with rollover sensors, respectively), it resulted in \$1,680 million net benefits

using a 3 percent discount rate, and \$1,217 million using a 7 percent discount rate. Both of these are based on a \$6.1 million cost per life,<sup>92</sup> as shown below.

*Analysis of Alternatives.* The following tables show the estimated benefits, costs, cost per equivalent life saved, and net benefits for the three alternative countermeasures considered.

Summers, S., et al., 19th International Technical Conference on the Enhanced Safety of Vehicles," paper number 05-0279, 2005. These benefits estimates are based on lateral rollovers. We do not know the effectiveness of these bags in other rollover events, such as end-to-end or more complex rolls. We suspect that the effectiveness would decrease noticeably in non-lateral rollovers.

<sup>90</sup> The benefit estimate was made based on particular assumptions used in the analysis. When inputs that affect the analysis are uncertain, the

agency makes its best judgment about the range of values that will occur through sensitivity analyses, as discussed in the PRIA. The sensitivity analyses showed that the ejection mitigation system would save as many as 581 lives in most favorable conditions and as little as 390 lives in least favorable conditions.

<sup>91</sup> Our analysis shows that most vehicles that are equipped with combination bags would be convertibles (about 1%). The agency asks for comments on whether it should exempt

convertibles from the ejection mitigation requirement on practicability grounds.

<sup>92</sup> The Department of Transportation has determined that the best current estimate of the economic value of preventing a human fatality is \$5.8 million ("Treatment of the Economic Value of a Statistical Life in Departmental Analyses," Tyler D. Duval, Assistant Secretary for Transportation Policy, February 5, 2008. The \$6.1 million comprehensive cost was based on the \$5.8 million statistical life.



TABLE 25—INCREMENTAL BENEFITS

Countermeasure	Weighted risk of ejection method		Uniform risk of ejection method	
	Fatalities	Serious injuries	Fatalities	Serious injuries
Full Curtain .....	402	310	390	296
A1 Full Curtain .....	391	301	372	283
Partial Curtain plus Laminated Glazing .....	494	391	490	386

TABLE 26—INCREMENTAL COSTS  
[In 2007 economics]

Countermeasure	Per average vehicle	Total (In millions)
Full Curtain .....	\$34	\$583
A1 Full Curtain .....	34	583
Partial Curtain plus Laminated Glazing .....	88	1,494

TABLE 27—COST PER EQUIVALENT LIFE SAVED AND NET BENEFITS

Countermeasure	Total cost	Weighted risk of ejection method				Uniform risk of ejection method			
		Cost per equivalent life saved		Net benefits		Cost per equivalent life saved		Net benefits	
		3%	7%	3%	7%	3%	7%	3%	7%
Full Curtain .....	\$583	\$1.57	\$1.98	\$1,680	\$1,217	\$1.63	\$2.04	\$1,605	\$1,158
A1 Full Curtain .....	583	1.62	2.03	1,615	1,166	1.68	2.11	1,534	1,101
Partial Curtain plus Laminated Glazing .....	1,494	3.27	4.11	1,292	723	3.30	4.14	1,271	706

The estimated benefits from the ejection mitigation systems considered show that the partial curtain plus front window laminated glazing system would result in most benefits (494 lives saved) followed by the full curtain and the A1 full curtain. However, the curtain plus glazing system would be the most costly system (\$1,624 million) followed by the full curtain and the A1 full curtain. When the comprehensive saving (for preventing a loss of statistical life) was considered, the net benefit analysis showed that the full curtain would result in the highest net benefits.

In the PRIA’s Sensitivity Analyses Section (Section VII), we analyzed costs and benefits that would result from the different assumptions used in the analysis. We seek public input on our analysis of costs and benefits under 100% belt use rate (one of NHTSA’s goals), and also under the scenario where alcohol-related crashes are removed from the analysis.

**X. Rulemaking Analyses and Notices**

*Executive Order 12866 (Regulatory Planning and Review) and DOT Regulatory Policies and Procedures*

The agency has considered the impact of this rulemaking action under

Executive Order 12866 and the Department of Transportation’s regulatory policies and procedures. This rulemaking is economically significant and was reviewed by the Office of Management and Budget under E.O. 12866, “Regulatory Planning and Review.” The rulemaking action has also been determined to be significant under the Department’s regulatory policies and procedures. NHTSA has placed in the docket a Preliminary Regulatory Impact Analysis (PRIA) describing the costs and benefits of this rulemaking action. The costs and benefits are summarized in section IX of this preamble.

*Regulatory Flexibility Act*

The Regulatory Flexibility Act of 1980, as amended, requires agencies to evaluate the potential effects of their proposed and final rules on small businesses, small organizations and small governmental jurisdictions. I hereby certify that this NPRM would not have a significant economic impact on a substantial number of small entities. Small organizations and small governmental units would not be significantly affected since the potential cost impacts associated with this

proposed action should not significantly affect the price of new motor vehicles.

The proposed rule would indirectly affect air bag manufacturers and suppliers. NHTSA believes these entities do not qualify as small entities.

The proposed rule would directly affect motor vehicle manufacturers. The PRIA discusses the economic impact of the proposed rule on small vehicle manufacturers, of which there are six. We believe that the proposed rule will not have a significant economic impact on these manufacturers. The standard would employ static testing of the ejection mitigation system. Small vehicle manufacturers are likely to certify compliance using a combination of component testing by air bag suppliers and engineering analyses. Already much of the ejection mitigation system development work for these small vehicle manufacturers is done by air bag suppliers. Typically, air bag suppliers will supply larger vehicle manufacturers during the development and phase-in period, and do not have the design capabilities to handle all of the smaller manufacturers. This rulemaking proposal accounts for this limitation by proposing to allow small manufacturers and limited line manufacturers to comply with the

upgraded requirements at the end of the phase-in period, to reduce the economic impact of the rule on these small entities.

NHTSA notes that final-stage vehicle manufacturers buy incomplete vehicles and complete the vehicle. Alterers modify new vehicles, such as by raising the roofs of vehicles. In either case, NHTSA tentatively concludes that the impacts of a final rule on such entities would not be significant. Final-stage manufacturers or alterers engaged in raising the roofs of vehicles would not be affected by this NPRM, because it proposes to exclude vehicles with raised roofs from the ejection mitigation requirements. NHTSA does not believe at this point that the ejection mitigation system would be affected by modifications other than the modification of the vehicle roof. Additional information concerning the potential impacts of the proposed requirements on small entities is presented in the PRIA.

#### *Executive Order 13132 (Federalism)*

NHTSA has examined today's proposed rule pursuant to Executive Order 13132 (64 FR 43255, August 10, 1999) and concluded that no additional consultation with States, local governments or their representatives is mandated beyond the rulemaking process. The agency has concluded that the proposed rule would not have sufficient federalism implications to warrant consultation with State and local officials or the preparation of a federalism summary impact statement. The proposal would not have "substantial direct effects on the States, on the relationship between the national government and the States, or on the distribution of power and responsibilities among the various levels of government."

Further, no consultation is needed to discuss the preemptive effect of today's proposed rule. NHTSA rules can have preemptive effect in two ways. First, the National Traffic and Motor Vehicle Safety Act contains an express preemptive provision: "When a motor vehicle safety standard is in effect under this chapter, a State or a political subdivision of a State may prescribe or continue in effect a standard applicable to the same aspect of performance of a motor vehicle or motor vehicle equipment only if the standard is identical to the standard prescribed under this chapter." 49 U.S.C. 30103(b)(1). It is this statutory command that unavoidably preempts State legislative and administrative law, not today's proposed rulemaking, so consultation would be unnecessary.

Second, the Supreme Court has recognized the possibility of implied preemption: In some instances, State requirements imposed on motor vehicle manufacturers, including sanctions imposed by State tort law, can stand as an obstacle to the accomplishment and execution of a NHTSA safety standard. When such a conflict is discerned, the Supremacy Clause of the Constitution makes the State requirements unenforceable. *See Geier v. American Honda Motor Co.*, 529 U.S. 861 (2000). However, NHTSA has considered the nature and purpose of today's proposed rule and does not foresee any potential State requirements that might conflict with it. Without any conflict, there could not be any implied preemption.

#### *Executive Order 12778 (Civil Justice Reform)*

With respect to the review of the promulgation of a new regulation, section 3(b) of Executive Order 12988, "Civil Justice Reform" (61 FR 4729, February 7, 1996) requires that Executive agencies make every reasonable effort to ensure that the regulation: (1) Clearly specifies the preemptive effect; (2) clearly specifies the effect on existing Federal law or regulation; (3) provides a clear legal standard for affected conduct, while promoting simplification and burden reduction; (4) clearly specifies the retroactive effect, if any; (5) adequately defines key terms; and (6) addresses other important issues affecting clarity and general draftsmanship under any guidelines issued by the Attorney General. This document is consistent with that requirement.

Pursuant to this Order, NHTSA notes as follows.

The issue of preemption is discussed above in connection with E.O. 13132. NHTSA notes further that there is no requirement that individuals submit a petition for reconsideration or pursue other administrative proceedings before they may file suit in court.

#### *Unfunded Mandates Reform Act*

The Unfunded Mandates Reform Act of 1995 (UMRA) requires Federal agencies to prepare a written assessment of the costs, benefits and other effects of proposed or final rules that include a Federal mandate likely to result in the expenditure by State, local or tribal governments, in the aggregate, or by the private sector, of more than \$100 million in any one year (\$100 million adjusted annually for inflation, with base year of 1995). These effects are discussed earlier in this preamble and in the PRIA.

UMRA also requires an agency issuing a final rule subject to the Act to select the "least costly, most cost-effective or least burdensome alternative that achieves the objectives of the rule." The preamble and the PRIA identify and consider several alternatives to the proposal, and the resulting cost and benefits of various potential countermeasures. The alternatives considered were: (a) Exclusion of the front lower corner of the front side window area (test point A1); (b) a component test consisting of a single headform impact at the center of the side window opening area; and, (c) a full-vehicle dynamic test to evaluate a countermeasure's retention capability instead of the headform component test proposed by this NPRM. The countermeasures examined for alternatives (a) and (b) were various levels of partial window coverage ("partial curtain"). We also examined the potential countermeasure of a partial curtain in combination with the installation of laminated glazing in the front window openings to prevent ejections through test point A1 and the lower gap ("partial curtain plus laminated glazing"). However, as discussed in this preamble and in the PRIA, none of these alternative proposals and potential countermeasures would fully achieve the objectives of the alternative preferred by NHTSA. The agency believes that it has selected the least costly, most cost-effective and least burdensome alternative that achieves the objectives of the rulemaking. The agency requests comments on this issue.

#### *National Environmental Policy Act*

NHTSA has analyzed this proposal for the purposes of the National Environmental Policy Act. The agency has determined that implementation of this action would not have any significant impact on the quality of the human environment.

#### *Plain Language*

Executive Order 12866 requires each agency to write all rules in plain language. Application of the principles of plain language includes consideration of the following questions:

Have we organized the material to suit the public's needs?

Are the requirements in the rule clearly stated?

Does the rule contain technical language or jargon that isn't clear?

Would a different format (grouping and order of sections, use of headings, paragraphing) make the rule easier to understand?

Would more (but shorter) sections be better?

Could we improve clarity by adding tables, lists, or diagrams?

What else could we do to make the rule easier to understand?

If you have any responses to these questions, please include them in your comments on this proposal.

#### *Paperwork Reduction Act (PRA)*

Under the PRA of 1995, a person is not required to respond to a collection of information by a Federal agency unless the collection displays a valid OMB control number. The proposal contains a collection of information, *i.e.*, the proposed phase-in reporting requirements, proposed requirements to place consumer information about the readiness indicator and about the sensor in the vehicle owner's manual (S4.2.3), and proposed requirements for providing information to NHTSA about a rollover sensor in a compliance test (S4.2.4). There is no burden to the general public.

The collection of information would require manufacturers of passenger cars and of trucks, buses and MPVs with a GVWR of 4,536 kg (10,000 lb) or less, to annually submit a report, and maintain records related to the report, concerning the number of such vehicles that meet the ejection mitigation requirements of this proposed FMVSS. The phase-in of the test requirements would be completed approximately seven years after publication of a final rule. The purpose of the reporting requirements would be to aid the agency in determining whether a manufacturer has complied with the ejection mitigation requirements during the phase-in of those requirements.

We are submitting a request for OMB clearance of the collection of information required under today's proposal. These requirements and our estimates of the burden to vehicle manufacturers are as follows:

- NHTSA estimates that there are 21 manufacturers of passenger cars, multipurpose passenger vehicles, trucks, and buses with a GVWR of 4,536 kg (10,000 lb) or less;
- NHTSA estimates that the total annual reporting and recordkeeping burden resulting from the collection of information is 1,260 hours;
- NHTSA estimates that the total annual cost burden, in U.S. dollars, will be \$0.

No additional resources would be expended by vehicle manufacturers to gather annual production information because they already compile this data for their own use.

Under the PRA, the agency must publish a document in the **Federal Register** providing a 60-day comment period and otherwise consult with members of the public and affected agencies concerning each collection of information. The Office of Management and Budget (OMB) has promulgated regulations describing what must be included in such a document. Under OMB's regulations (5 CFR 320.8(d)), agencies must ask for public comment on the following:

(1) Whether the collection of information is necessary for the proper performance of the functions of the agency, including whether the information will have practical utility;

(2) The accuracy of the agency's estimate of the burden of the proposed collection of information, including the validity of the methodology and assumptions used;

(3) How to enhance the quality, utility, and clarity of the information to be collected; and,

(4) How to minimize the burden of the collection of information on those who are to respond, including the use of appropriate automated, electronic, mechanical, or other technological collection techniques or other forms of information technology, *e.g.*, permitting electronic submission of responses.

Organizations and individuals that wish to submit comments on the information collection requirements should direct them to NHTSA's docket for this NPRM.

#### *National Technology Transfer and Advancement Act*

Under the National Technology Transfer and Advancement Act of 1995 (NTTAA) (Pub. L. 104-113), all Federal agencies and departments shall use technical standards that are developed or adopted by voluntary consensus standards bodies, using such technical standards as a means to carry out policy objectives or activities determined by the agencies and departments.

Voluntary consensus standards are technical standards (*e.g.*, materials specifications, test methods, sampling procedures, and business practices) that are developed or adopted by voluntary consensus standards bodies, such as the International Organization for Standardization (ISO) and the Society of Automotive Engineers. The NTTAA directs us to provide Congress, through OMB, explanations when we decide not to use available and applicable voluntary consensus standards. NHTSA has searched for, but has not found, any applicable voluntary consensus standards.

## **XI. Public Participation**

In developing this proposal, we tried to address the concerns of all our stakeholders. Your comments will help us improve this proposed rule. We invite you to provide different views on options we propose, new approaches we haven't considered, new data, how this proposed rule may affect you, or other relevant information. We welcome your views on all aspects of this proposed rule, but request comments on specific issues throughout this document. Your comments will be most effective if you follow the suggestions below:

- Explain your views and reasoning as clearly as possible.
- Provide solid technical and cost data to support your views.
- If you estimate potential costs, explain how you arrived at the estimate.
- Tell us which parts of the proposal you support, as well as those with which you disagree.
- Provide specific examples to illustrate your concerns.
- Offer specific alternatives.
- Refer your comments to specific sections of the proposal, such as the units or page numbers of the preamble, or the regulatory sections.
- Be sure to include the name, date, and docket number with your comments.

Your comments must be written and in English. To ensure that your comments are correctly filed in the docket, please include the docket number of this document in your comments.

Your comments must not be more than 15 pages long (49 CFR 553.21). We established this limit to encourage you to write your primary comments in a concise fashion. However, you may attach necessary additional documents to your comments. There is no limit on the length of the attachments.

Please submit your comments to the docket electronically by logging onto <http://www.regulations.gov> or by the means given in the **ADDRESSES** section at the beginning of this document.

#### *How Do I Submit Confidential Business Information?*

If you wish to submit any information under a claim of confidentiality, you should submit three copies of your complete submission, including the information you claim to be confidential business information, to the Chief Counsel, NHTSA, at the address given above under **FOR FURTHER INFORMATION CONTACT**. In addition, you should submit a copy from which you have deleted the claimed confidential business information to the docket.

When you send a comment containing information claimed to be confidential business information, you should include a cover letter setting forth the information specified in our confidential business information regulation. (49 CFR Part 512.)

#### *Will the Agency Consider Late Comments?*

We will consider all comments that the docket receives before the close of business on the comment closing date indicated above under **DATES**. To the extent possible, we will also consider comments that the docket receives after that date. If the docket receives a comment too late for us to consider it in developing a final rule (assuming that one is issued), we will consider that comment as an informal suggestion for future rulemaking action.

#### *How Can I Read the Comments Submitted by Other People?*

You may read the comments received by the docket at the address given above under **ADDRESSES**. You may also see the comments on the Internet (<http://regulations.gov>).

Please note that even after the comment closing date, we will continue to file relevant information in the docket as it becomes available. Further, some people may submit late comments. Accordingly, we recommend that you periodically check the docket for new material.

Anyone is able to search the electronic form of all comments received into any of our dockets by the name of the individual submitting the comment (or signing the comment, if submitted on behalf of an association, business, labor union, etc.). You may review DOT's complete Privacy Act Statement in the **Federal Register** published on April 11, 2000 (Volume 65, Number 70; Pages 19477–78).

#### **List of Subjects**

##### *49 CFR Part 571*

Imports, Incorporation by reference, Motor vehicle safety, Reporting and recordkeeping requirements, Tires.

##### *49 CFR Part 585*

Motor vehicle safety, Reporting and recordkeeping requirements, Incorporation by reference.

In consideration of the foregoing, NHTSA proposes to amend 49 CFR parts 571 and 585 as set forth below.

#### **PART 571—FEDERAL MOTOR VEHICLE SAFETY STANDARDS**

1. The authority citation for Part 571 continues to read as follows:

**Authority:** 49 U.S.C. 322, 30111, 30115, 30117 and 30166; delegation of authority at 49 CFR 1.50.

2. Section 571.5(b) would be amended by redesignating paragraph (11) as paragraph (12), and by adding new paragraph (11) to read as follows:

##### **§ 571.5 Matter incorporated by reference.**

\* \* \* \* \*

(b) \* \* \*

(11) *Ejection Mitigation Headform Drawing Package*. Copies may be obtained by contacting: Reprographics Technologies, 9000 Virginia Manor Rd., Beltsville, MD 20705, telephone (301) 210-5600.

\* \* \* \* \*

3. Section 571.226 would be added to read as follows:

##### **§ 571.226 Standard No. 226; Ejection Mitigation.**

*S1. Purpose and Scope.* This standard establishes requirements for ejection mitigation systems to reduce the likelihood of complete and partial ejections of vehicle occupants through side windows during rollovers or side impact events.

*S2. Application.* This standard applies to passenger cars, and to multipurpose passenger vehicles, trucks and buses with a gross vehicle weight rating of 4,536 kg or less, except walk-in vans and modified roof vehicles.

##### *S3. Definitions.*

*Ejection impactor* means a device specified in S7.1 of this Standard No. 226 that is a component of the ejection mitigation test device and is the moving mass that strikes the ejection mitigation countermeasure. It consists of an ejection headform attached to a shaft.

*Ejection impactor targeting point* means the intersection of the y-axis of the ejection headform and the outer surface of the ejection headform.

*Ejection mitigation countermeasure* means a device or devices, except seat belts, integrated into the vehicle that reduce the likelihood of occupant ejection through a side window opening, and that requires no action by the occupant for activation.

*Ejection propulsion mechanism* means a device specified in S7.2 of this Standard No. 226 that is a component of the ejection mitigation test device consisting of a mechanism capable of propelling the ejection impactor and constraining it to move along its axis or shaft.

*Limited-line manufacturer* means a manufacturer that sells three or fewer carlines, as that term is defined in 49 CFR 583.4, in the United States during a production year.

*Modified roof* means the replacement roof on a motor vehicle whose original

roof has been removed, in part or in total.

*Row* means a set of one or more seats whose seat outlines do not overlap with the seat outline of any other seats, when all seats are adjusted to their rearmost normal riding or driving position, when viewed from the side.

*Seat outline* means the outer limits of a seat projected laterally onto a vertical longitudinal vehicle plane.

*Side daylight opening* means, other than a door opening, the locus of all points where a horizontal line, perpendicular to the vehicle vertical longitudinal plane, is tangent to the periphery of the opening, including the area 50 millimeters inboard of the window glazing, but excluding any flexible gasket material or weather stripping used to create a waterproof seal between the glazing and the vehicle interior.

*Small manufacturer* means an original vehicle manufacturer that produces or assembles fewer than 5,000 vehicles annually for sale in the United States.

*Target* means target outline.

*Target outline* means the x-z plane projection of the ejection headform face as shown in Figure 1.

*Walk-in van* means a special cargo/mail delivery vehicle that has only one designated seating position. That designated seating position must be forward facing and for use only by the driver. The vehicle usually has a thin and light sliding (or folding) side door for easy operation and a high roof clearance that enables a person of medium stature to enter the passenger compartment area in an upright position.

*Zero displacement plane* means, a vertical plane parallel to the vehicle longitudinal centerline and tangent to the most outboard surface of the ejection headform when the headform is aligned with an impact target location and just touching the inside surface of a window covering the side daylight opening.

*S4. Phase-in, performance and other requirements.*

##### *S4.1 Phase-in requirements.*

*S4.1.1* Except as provided in S4.1.3 of this Standard No. 226, for vehicles manufactured on or after [date first September 1 three full years after the publication date of the final rule; for illustration purposes, assume that the date is September 1, 2014] to [date that is the August 31 that is seven years after the publication date of the final rule; for illustration purposes, August 31, 2017], a percentage of each manufacturer's production, as specified in S8, shall meet the requirements of S4.2. Vehicles that are not subject to the phase-in may

be certified as meeting the requirements specified in this Standard No. 226.

S4.1.2 Except as provided in S4.1.3 of this section, each vehicle manufactured on or after September 1, 2017 [date provided for illustration purposes] must meet the requirements of S4.2.

S4.1.3 *Exceptions from the phase-in; special allowances.*

(a) Vehicles produced by a small manufacturer and by a limited line manufacturer are not subject to S4.1.1 of this Standard No. 226, but are subject to S4.1.2.

(b) Vehicles that are altered (within the meaning of 49 CFR 567.7) before September 1, 2018 [dates provided in this section are for illustration purposes], after having been previously certified in accordance with part 567 of this chapter, and vehicle manufactured in two or more stages before September 1, 2018, are not required to meet the requirements of S4.2. Vehicles that are altered on or after September 1, 2018, and vehicles that are manufactured in two or more stages on or after September 1, 2018, must meet the requirements of S4.2.

S4.2 *Performance and other requirements.*

S4.2.1 When the ejection propulsion mechanism propels the ejection impactor into the impact target locations of each side daylight opening of a vehicle according to the test procedures specified in S5 of this Standard No. 226, the most outboard surface of the ejection headform must not displace more than 100 millimeters beyond the zero displacement plane.

S4.2.2 Vehicles that have an ejection mitigation countermeasure that deploys in the event of a rollover must have a monitoring system with a readiness indicator. The indicator shall monitor its own readiness and must be clearly visible from the driver's designated seating position. The same readiness indicator required by S4.5.2 of FMVSS No. 208 may be used to meet the requirement. A list of the elements of the system being monitored by the indicator shall be included with the information furnished in accordance with S4.2.3.

S4.2.3 *Written information.*

(a) Vehicles with an ejection mitigation countermeasure that deploys in the event of a rollover must be described as such in the vehicle's owner manual or in other written information provided by the vehicle manufacturer to the consumer.

(b) Vehicles that have an ejection mitigation countermeasure that deploys in the event of a rollover must include in written information a discussion of

the readiness indicator required by S4.2.2, specifying a list of the elements of the system being monitored by the indicator, a discussion of the purpose and location of the telltale, and instructions to the consumer on the steps to take if the telltale is illuminated.

S4.2.4 *Technical Documentation.*

For vehicles that have an ejection mitigation countermeasure that deploys in the event of a rollover, the vehicle manufacturer must make available to the agency, upon request, the following information: A discussion of the sensor system used to deploy the countermeasure, including the pertinent inputs to the computer or calculations within the computer and how its algorithm uses that information to determine if the countermeasure should be deployed.

S5. *Test procedures.*

S5.1 Demonstrate compliance with S4.2 of this Standard No. 226 in accordance with the test procedures specified in this standard, under the conditions of S6, using the equipment described in S7. In the impact test described by these procedures, target locations are identified (S5.2) and the zero displacement plane location is determined (S5.3). The glazing is pre-broken, fully retracted or removed prior to the impact test (S5.4). The countermeasure is deployed, if applicable, and an ejection impactor (see S7.1) strikes impact target locations at specified speeds and times (S5.5). The lateral displacement of the ejection impactor beyond the zero displacement plane is measured.

S5.2 *Determination impact target locations.* To identify the impact target locations, the following procedures are performed with the x and z axes of the target outline, shown in Figure 1 (provided for illustration purposes), aligned within  $\pm 1$  degree of the vehicle longitudinal and vertical axes, respectively, and the x-z plane of the target outline within  $\pm 1$  degree of a vehicle vertical longitudinal plane.

S5.2.1 *Preliminary target locations.*

(a) Determine the location of an offset-line within the daylight opening by projecting each point of the side daylight opening laterally onto a vehicle vertical longitudinal plane. Move each point by  $25 \pm 2$  mm towards the center of the side daylight opening and perpendicular to a line tangent to the projection at that point, while maintaining the point on a vehicle vertical longitudinal plane.

(b) Place target outlines at any location inside the offset-line where the target outline is tangent to within  $\pm 2$  mm of the offset-line at just two or three

points (see Figure 2) (figure provided for illustration purposes).

S5.2.2 *Determination of primary target locations.* Divide the side daylight opening into four quadrants by passing a vertical line and a horizontal line, in a vehicle vertical longitudinal plane, through the geometric center of the daylight opening.

S5.2.2.1 *Front windows.* For any side daylight opening forward of the vehicle B-pillar, the primary quadrants are the forward-lower and rearward-upper.

S5.2.2.2 *Rear windows.* For any side daylight opening rearward of the B-pillar, the primary quadrants are the forward-upper and rearward-lower.

S5.2.2.3 The primary targets have outlines whose center is within the primary quadrants, regardless of the location of the primary quadrant outline. If there is more than one target outline center in each primary target quadrant, maintain the lowest target outline in the lower quadrants and the highest targets in the upper quadrants. If there is a primary quadrant that does not contain a target outline center, the target outline whose center is closest to the primary quadrant outline becomes the primary target (see Figure 3) (figure provided for illustration purposes).

S5.2.3 *Determination of secondary target locations.*

S5.2.3.1 *Front windows.* Measure the horizontal distance between the centers of the primary target outlines. For a side daylight opening forward of the B-pillar, place one secondary target outline centered rearward of the forward primary target by one-third of the horizontal distance between the primary target outlines and tangent with upper portion of the offset-line. Place another secondary target outline centered rearward of the forward primary target by two-thirds of the horizontal distance between the primary target outlines and tangent with the lower portion of the offset-line (see figure 4) (figure provided for illustration purposes).

S5.2.3.2 *Rear windows.* For side daylight openings rearward of the B-pillar, place one secondary target outline centered rearward of the forward primary target by one-third of the horizontal distance between the primary target outlines and tangent with lower portion of the offset-line. Place another secondary target outline centered rearward of the forward primary target by two-thirds of the horizontal distance between the primary target outlines and tangent with the upper portion of the offset-line (see Figure 4) (figure provided for illustration purposes).

S5.2.4 *Target adjustment.*

5.2.4.1 *Target elimination and reconstitution.*  
 5.2.4.1.1 *Target elimination.* Determine the horizontal and vertical distance between the centers of the targets. If the horizontal distance between the target centers is less than 135 mm and the vertical distance is less

than 170 mm, eliminate the targets in the order of priority given in steps 1 through 4 of Table 1 (see Figure 5) (figure provided for illustration purposes). In each case, both the target centers must be closer than 135 mm and 170 mm in the horizontal and vertical

directions, respectively. If the horizontal distance between the targets is not less than 135 mm or the vertical distance is not less than 170 mm, do not eliminate the target. Continue checking all the targets listed in steps 1 through 4 of Table 1.

TABLE 1—PRIORITY LIST OF TARGET DISTANCE TO BE CHECKED AGAINST HORIZONTAL AND VERTICAL LIMITS

Step	Measure distance of these target centers	Eliminate this target if horizontal and vertical distances are less than 135 mm and 170 mm, respectively*
1	Upper Secondary to Lower Secondary	Upper Secondary.
2	Upper Primary to Upper or Remaining Secondary	Upper or Remaining Secondary.
3	Lower Primary to Lower or Remaining Secondary	Lower or Remaining Secondary.
4	Upper Primary to Lower Primary	Upper Primary.

\*The target centers must be closer than 135 mm and 170 mm in the x and z directions, respectively.

5.2.4.1.2 *Target reconstitution.* If after following the procedure given in S5.2.4.1.1, there are only two targets remaining, determine the absolute distance between the centers of these targets. If this distance is greater than or equal to 360 mm, place a target such that the center of its outline bisects a line connecting the centers of the remaining targets.

5.2.4.2 *Rearmost target location.*

(a) Except as provided in S5.2.4.2(b), if a side daylight opening extends rearward of a transverse vertical vehicle plane located 600 mm behind (1) the seating reference point of the last row seat adjacent to the opening, in the case of a vehicle with fewer than 3 rows, or (2) the 3rd row seat adjacent to the opening, in the case of a vehicle with 3 or more seating rows, the transverse vertical vehicle plane defines the rearward edge of the daylight opening for the purposes of determining target locations.

(b) When the last row seat adjacent to the opening, in the case of a vehicle with fewer than 3 rows, or the 3rd row seat adjacent to the opening, in the case of a vehicle with 3 or more seating, is not fixed in the forward facing direction, the side daylight opening may extend farther rearward than specified in S5.2.4.2(a) under the following conditions. With the seat in any non-forward facing orientation, the seat back set at an inclination position closest to the manufacturer's design seat back angle, and all other seat adjustments at any potential position of adjustment, determine the location of a vertical lateral vehicle plane located 600 mm behind the rearmost portion of the seat. The target area extends to this vertical plane if it is farther rearward than the plane determined in S5.2.4.2(a).

5.3 *Determination of zero displacement plane.* The glazing

covering the target location of the side daylight opening being tested is intact and in place in the case of fixed glazing and intact and fully closed in the case of movable glazing. With the ejection impactor targeting point aligned within  $\pm 2$  mm of the center of any target location specified in S5.2, and with the ejection impactor on the inside of the vehicle, slowly move the impactor towards the window until contact is made with the interior of the glazing with no more than 20 N of pressure being applied to the window. The location of the most outboard surface of the headform establishes the zero displacement plane for this target location.

5.4 *Window position.* Prior to impact testing, the glazing covering the target location must be removed from the side daylight opening, fully retracted, or pre-broken according to the procedure in S5.4.1, at the option of the vehicle manufacturer.

5.4.1 *Window glazing pre-breaking procedure.*

5.4.1.1 *Breakage pattern.* Locate the geometric center of the daylight opening, established in S5.2.2 of this Standard No. 226. Mark the surface of the window glazing in a horizontal and vertical grid of points separated by  $50 \pm 2$  mm with one point coincident within  $\pm 2$  mm of the geometric center of the daylight opening (see Figure 6) (figure provided for illustration purposes).

5.4.1.2 *Breakage method.*

(a) Start with the inside surface of the window and forward-most, lowest mark made as specified in S5.4.1.1 of this Standard No. 226. Use a center punch to make a hole in the glazing. The punch tip has a  $5 \pm 2$  mm diameter prior to coming to a point. The spring is adjusted to require  $150 \pm 25$  N of force to activate the punch. Apply pressure to the center punch in a direction  $\pm 10$

degrees perpendicular to the window surface.

(b) Use a  $100 \pm 10$  mm  $\times$   $100 \pm 10$  mm piece of rigid material as a reaction surface on the opposite side of the glazing to prevent to the extent possible the window surface from deforming by more than 10 mm when pressure is being applied to the hole-punch.

(c) Continue making holes by moving rearward in the grid until the end of a row is reached. Then move to the forward-most mark on the next higher row and make a hole. Continue in this pattern until all the holes on the inside surface of the glazing are made.

(d) Repeat the process on the outside surface of the window.

(e) If punching a hole causes the glazing to disintegrate, halt the breakage procedure and proceed with the headform impact test.

5.5 *Impact speeds and time delays.*

(a) *Vehicles with an ejection mitigation countermeasure that deploys in a rollover.* Using the ejection propulsion mechanism, propel the ejection impactor such that it strikes:

(1) Any target location specified in S5.2 of this Standard No. 226,  $6.0 \pm 0.1$  seconds after activation of an ejection mitigation countermeasure that deploys in the event of a rollover and at a velocity of  $16 \pm 0.5$  km/h; and,

(2A) [Alternative 1 to paragraph (2)] Any target location specified in S5.2 of this Standard No. 226,  $1.5 \pm 0.1$  seconds after activation of an ejection mitigation countermeasure that deploys in the event of a rollover and at a velocity of  $24 \pm 0.5$  km/h.

(2B) [Alternative 2 to paragraph (2)] The target location struck in accordance with S5.5(a) that resulted in the greatest amount of displacement of the ejection impactor beyond the zero displacement plane,  $1.5 \pm 0.1$  seconds after activation of an ejection mitigation

countermeasure that deploys in the event of a rollover and at a velocity of  $24 \pm 0.5$  km/h.

(b) *Vehicles without an ejection mitigation countermeasure that deploys in a rollover.* Using the ejection propulsion mechanism, propel the ejection impactor such that it strikes the target location at a velocity of  $16 \pm 0.5$  km/h and at a velocity of  $24 \pm 0.5$  km/h. Do not deploy inflatable devices at any time during the test or activate any other ejection mitigation countermeasure.

(c) An ejection mitigation countermeasure that deploys in the event of a rollover is described as such in the vehicle's owner manual or in other written information provided by the vehicle manufacturer to the consumer.

**S5.6 Ejection impactor orientation.** At the time of launch of the ejection impactor the:

(a) x and z axes of the ejection headform must be aligned within  $\pm 1$  degree of the vehicle longitudinal and vertical axes, respectively; and,

(b) y axis of the ejection headform must be within  $\pm 1$  degree of the vehicle lateral axis.

**S6. General test conditions.**

**S6.1 Vehicle test attitude.** The vehicle is supported off its suspension at an attitude determined in accordance with S6.1(a) and (b).

(a) The vehicle is loaded to its unloaded vehicle weight.

(b) All tires are inflated to the manufacturer's specifications listed on the vehicle's tire placard.

**S6.2 Doors.**

(a) Except as provided in S6.2(b) or S6.2(c), doors, including any rear hatchback or tailgate, are fully closed and latched but not locked.

(b) During testing, any side door on the opposite side of the longitudinal centerline of the vehicle from the target to be impacted may be open or removed.

(c) During testing, any rear hatchback or tailgate may be open or removed for testing any target.

**S6.3 Steering wheel and seats.**

During targeting and testing, the steering wheel and seats may be removed from the vehicle.

**S6.4 Convertible tops.** During testing, the top, if any, of convertibles and open-body type vehicles is in the closed passenger compartment configuration.

**S6.5 Temperature and humidity.**

(a) During testing, the ambient temperature is between 18 degrees C. and 29 degrees C., at any relative humidity between 10 percent and 70 percent.

(b) The headform specified in S7.1.1 of this Standard No. 226 is exposed to

the conditions specified in S6.5(a) for a continuous period not less than one hour, prior to the test.

**S7. sEjection mitigation test device specifications.** The ejection mitigation test device consists of an ejection impactor and ejection propulsion mechanism with the following specifications. The ability of a test device to meet these specifications may be determined outside of the vehicle.

**S7.1 Ejection impactor.** The ejection impactor has a mass of  $18 \text{ kg} \pm 0.05 \text{ kg}$ . The shaft is parallel to the y axis of the headform.

**S7.1.1 Ejection headform dimensions.** The ejection headform has the dimensions shown in Figure 1 and is depicted in Ejection Mitigation Headform Drawing Package, dated 2007 (incorporated by reference; see § 571.5).

**S7.1.2 Static deflection.** The ejection headform must not deflect downward more than 20 mm when a 27 kg mass is attached to the posterior surface of the headform. The center of gravity of the attached mass is aligned with the axis of motion of the impactor and 100 mm rear of the impact face. The static deflection measurement is made with the ejection impactor attached to the ejection propulsion mechanism and extended 300 mm outboard of the theoretical point of impact with the countermeasure.

**S7.2 Frictional characteristics.**

**S7.2.1 Unobstructed velocity reduction.** If unobstructed, the ejection impactor must not lose more than 10 percent of the 24 km/h velocity and 15 percent of the 16 km/h velocity specified in S5.5 of this Standard No. 226 in 300 mm of outboard travel from the theoretical point of impact with the ejection mitigation countermeasure.

**S7.2.2 Obstructed push force.** The average force necessary to move the ejection impactor 225 mm rearward into the ejection propulsion mechanism at a rate of  $50 (\pm 13)$  mm per second, starting at a point 300 mm outboard of the theoretical point of impact with the countermeasure, must not exceed 570 N and have a standard deviation of no more than 30 N. The measurement is made with the 27 kg mass specified in S7.1.2 of this Standard No. 226 attached to the headform, excludes the force measured over the first 25 mm of travel and is recorded at a frequency of 100 Hz. The force is applied to the ejection headform with the skin removed.

**S7.3 Targeting accuracy.** Determine the distance "D" along the axis of travel of the ejection impactor from its launch point to the theoretical point of impact with the countermeasure, when moving at the speed specified in S5.5.

Determine that the ejection mitigation

test device can deliver the ejection impactor targeting point to within  $\pm 10$  mm of an axis normal to and passing through the target outline center, as the unobstructed impactor passes through a zone defined by vertical longitudinal planes 50 mm forward and rearward of "D."

**S8. Phase-in Schedule for Vehicle Certification.**

**S8.1 Vehicles manufactured on or after September 1, 2014 and before September 1, 2016.** At anytime during the production years ending August 31, 2015, August 31, 2016, August 31, 2016, and August 31, 2017, each manufacturer shall, upon request from the Office of Vehicle Safety Compliance, provide information identifying the vehicles (by make, model and vehicle identification number) that have been certified as complying with this standard. The manufacturer's designation of a vehicle as a certified vehicle is irrevocable.

**S8.2 Vehicles manufactured on or after September 1, 2014 and before September 1, 2015.** Subject to S8.8, for vehicles manufactured on or after September 1, 2014 and before September 1, 2015, the number of vehicles complying with S4.2 shall be not less than 20 percent of:

(a) The manufacturer's average annual production of vehicles manufactured in the three previous production years; or

(b) The manufacturer's production in the current production year.

**S8.3 Vehicles manufactured on or after September 1, 2015 and before September 1, 2016.** Subject to S8.8, for vehicles manufactured on or after September 1, 2015 and before September 1, 2016, the number of vehicles complying with S4.2 shall be not less than 40 percent of:

(a) The manufacturer's average annual production of vehicles manufactured in the three previous production years; or

(b) The manufacturer's production in the current production year.

**S8.4 Vehicles manufactured on or after September 1, 2016 and before September 1, 2017.** Subject to S8.8, for vehicles manufactured on or after September 1, 2016 and before September 1, 2017, the number of vehicles complying with S4.2 shall be not less than 75 percent of:

(a) The manufacturer's average annual production of vehicles manufactured in the three previous production years; or

(b) The manufacturer's production in the current production year.

**S8.5 Vehicles produced by more than one manufacturer.** For the purpose of calculating average annual production of vehicles for each manufacturer and the number of vehicles manufactured by each

manufacturer under S8.1 through S8.4, a vehicle produced by more than one manufacturer shall be attributed to a single manufacturer as follows, subject to S8.6.

(a) A vehicle that is imported shall be attributed to the importer.

(b) A vehicle manufactured in the United States by more than one manufacturer, one of which also markets the vehicle, shall be attributed to the manufacturer that markets the vehicle.

S8.6 A vehicle produced by more than one manufacturer shall be attributed to any one of the vehicle's manufacturers specified by an express written contract, reported to the National Highway Traffic Safety Administration under 49 CFR part 585, between the manufacturer so specified and the manufacturer to which the

vehicle would otherwise be attributed under S8.5.

S8.7 For the purposes of calculating average annual production of vehicles for each manufacturer and the number of vehicles manufactured by each manufacturer under S8, do not count any vehicle that is excluded by this standard from the requirements.

S8.8 *Calculation of complying vehicles.*

(a) For the purposes of calculating the vehicles complying with S8.2, a manufacturer may count a vehicle if it is manufactured on or after [date that is 30 days after publication of the final rule in the **Federal Register**] but before September 1, 2015.

(b) For purposes of complying with S8.3, a manufacturer may count a vehicle if it—

(1) Is manufactured on or after [date that is 30 days after publication of the

final rule in the **Federal Register** but before September 1, 2016 and,

(2) Is not counted toward compliance with S8.2.

(c) For purposes of complying with S8.4, a manufacturer may count a vehicle if it—

(1) Is manufactured on or after [date that is 30 days after publication of the final rule in the **Federal Register**] but before September 1, 2017 and,

(2) Is not counted toward compliance with S8.2 or S8.3.

(d) For the purposes of calculating average annual production of vehicles for each manufacturer and the number of vehicles manufactured by each manufacturer, each vehicle that is excluded from having to meet the applicable requirement is not counted.

Figures to § 571.226.

BILLING CODE 4910-59-P

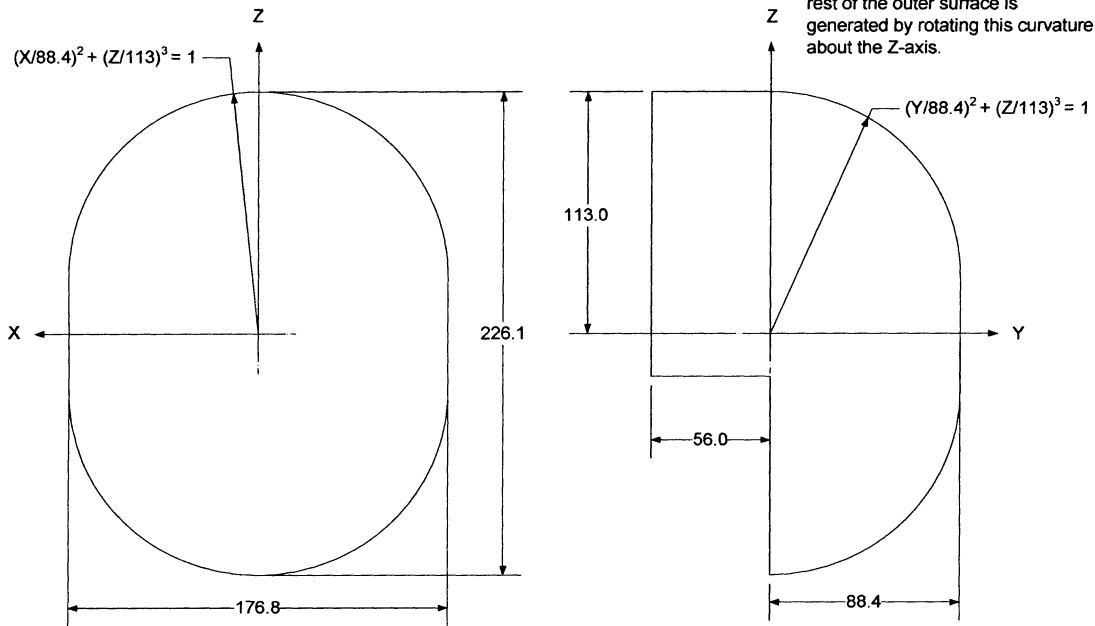

Figure 1 – Ejection Headform Face. All dimensions are millimeters.



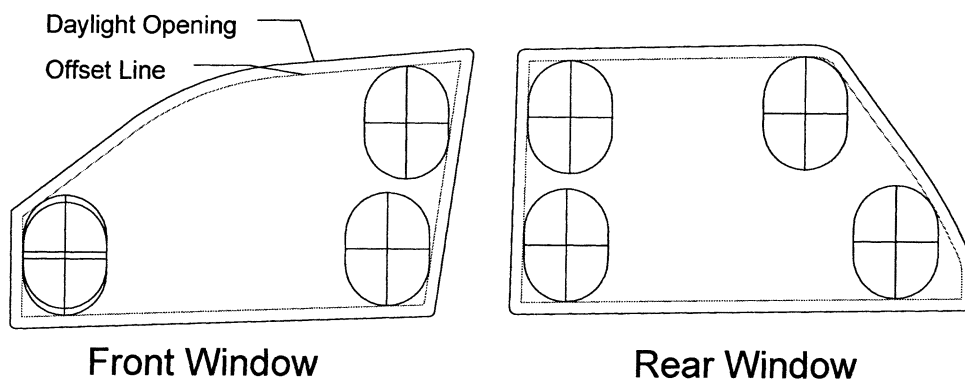

Figure 2

Identify Primary Targets

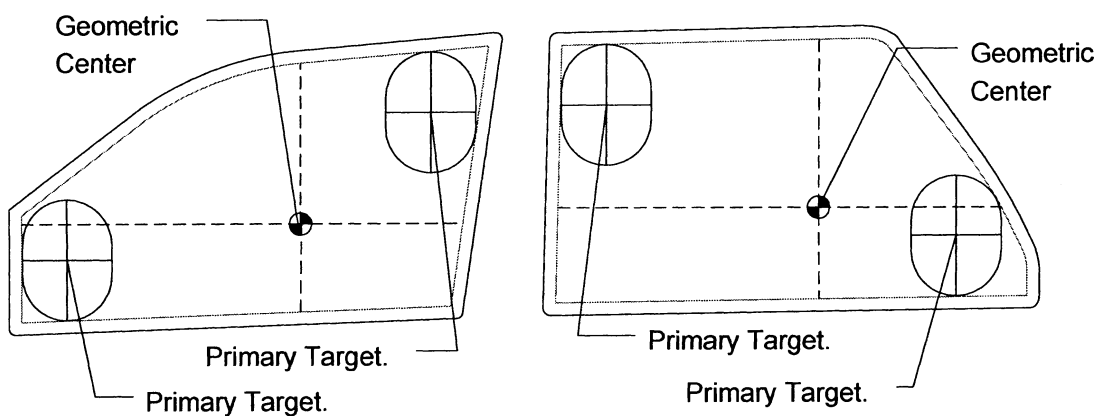

Figure 3

Final Target Locations

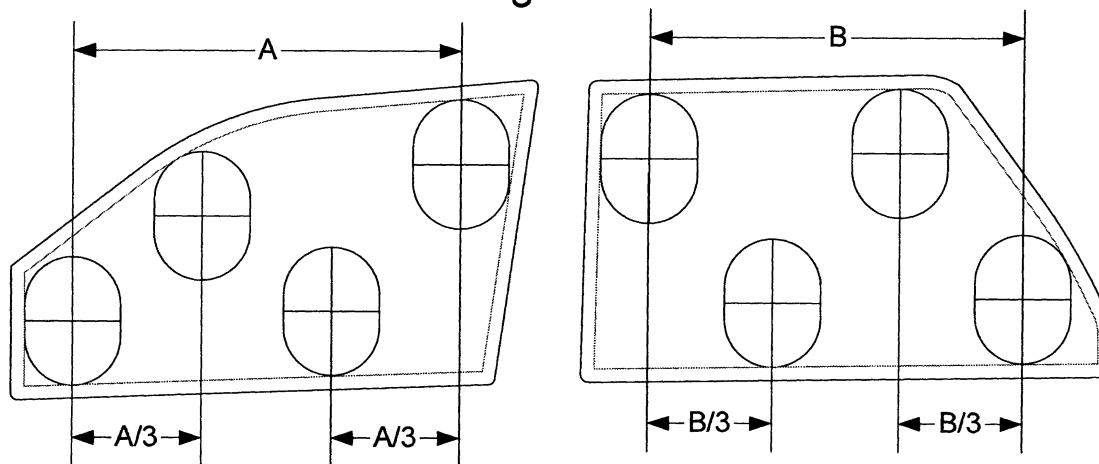

Figure 4

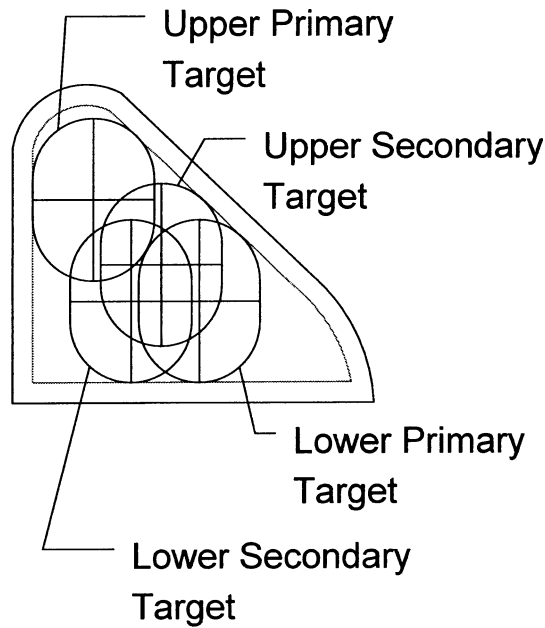

Figure 5

50 mm by 50 mm Hole Punch Pattern

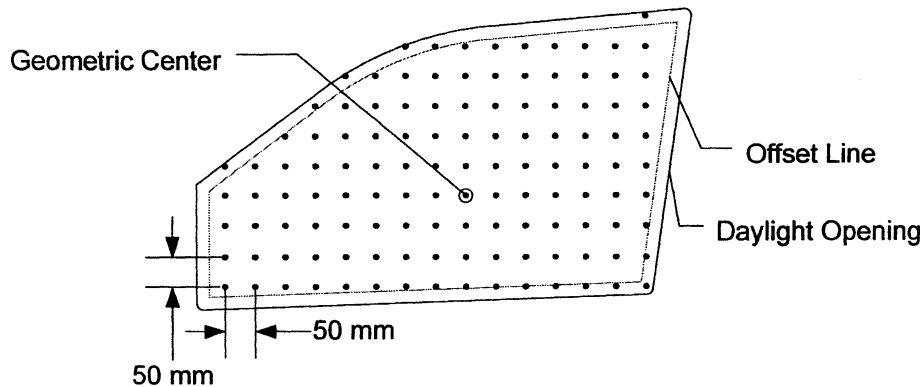

Figure 6

BILLING CODE 4910-59-C

**PART 585—PHASE-IN REPORTING REQUIREMENTS**

4. The authority citation for part 585 would continue to read as follows:

**Authority:** 49 U.S.C. 322, 30111, 30115, 30117, and 30166; delegation of authority at 49 CFR 1.50.

5. Part 585 would be amended by adding Subpart K to read as follows:

\* \* \* \* \*

**Subpart K—Ejection Mitigation Phase-in Reporting Requirements**

- Sec.
- 585.100 Scope.
- 585.101 Purpose.

- 585.102 Applicability.
- 585.103 Definitions.
- 585.104 Response to inquiries.
- 585.105 Reporting requirements.
- 585.106 Records.

**§ 585.100 Scope.**

This part establishes requirements for manufacturers of passenger cars, and of trucks, buses and multipurpose passenger vehicles with a gross vehicle weight rating (GVWR) of 4,536 kilograms (kg) (10,000 pounds (lb)) or less, to submit a report, and maintain records related to the report, concerning the number of such vehicles that meet the ejection mitigation requirements of Standard No. 226, *Ejection mitigation* (49 CFR 571.226).

**§ 585.101 Purpose.**

The purpose of these reporting requirements is to assist the National Highway Traffic Safety Administration in determining whether a manufacturer has complied with the requirements of Standard No. 226, *Ejection mitigation* (49 CFR 571.226).

**§ 585.102 Applicability.**

This part applies to manufacturers of passenger cars, and of trucks, buses and multipurpose passenger vehicles with a GVWR of 4,536 kg (10,000 lb) or less. However, this part does not apply to vehicles excluded by Standard No. 226 (49 CFR 571.226) from the requirements of that standard.

**§ 585.103 Definitions.**

(a) All terms defined in 49 U.S.C. 30102 are used in their statutory meaning.

(b) Bus, gross vehicle weight rating or GVWR, multipurpose passenger vehicle, passenger car, and truck are used as defined in § 571.3 of this chapter.

(c) Production year means the 12-month period between September 1 of one year and August 31 of the following year, inclusive.

(d) Limited line manufacturer means a manufacturer that sells three or fewer carlines, as that term is defined in 49 CFR 583.4, in the United States during a production year.

**§ 585.104 Response to inquiries.**

At anytime during the production years ending August 31, 2015, August 31, 2016, and August 31, 2017, each manufacturer shall, upon request from the Office of Vehicle Safety Compliance, provide information identifying the vehicles (by make, model and vehicle identification number) that have been certified as complying with the ejection mitigation requirements of Standard No. 226, *Ejection mitigation* (49 CFR 571.226). The manufacturer's designation of a vehicle as a certified vehicle is irrevocable.

**§ 585.105 Reporting requirements.**

(a) *Advanced credit phase-in reporting requirements.* (1) Within 60 days after the end of the production

years ending August 31, 2011, August 31, 2012, August 31, 2013, and August 31, 2014, each manufacturer choosing to certify vehicles manufactured during any of those production years as complying with the ejection mitigation requirements of Standard No. 226 (49 CFR 571.226) shall submit a report to the National Highway Traffic Safety Administration providing the information specified in paragraph (c) of this section and in § 585.2 of this part.

(b) *Phase-in reporting requirements.* Within 60 days after the end of each of the production years ending August 31, 2015, August 31, 2016, and August 31, 2017, each manufacturer shall submit a report to the National Highway Traffic Safety Administration concerning its compliance with the ejection mitigation requirements of Standard No. 226 (49 CFR 571.226) for its vehicles produced in that year. Each report shall provide the information specified in paragraph (d) of this section and in section 585.2 of this part.

(c) *Advanced credit phase-in report content—(1) Production of complying vehicles.* With respect to the reports identified in § 585.105(a), each manufacturer shall report for the production year for which the report is filed the number of vehicles, by make and model year, that are certified as meeting the ejection mitigation requirements of Standard No. 226 (49 CFR 571.226).

(d) *Phase-in report content—*

(1) *Basis for phase-in production goals.* Each manufacturer shall provide the number of vehicles manufactured in the current production year, or, at the manufacturer's option, in each of the three previous production years. A new manufacturer that is, for the first time, manufacturing passenger cars for sale in the United States must report the number of passenger cars manufactured during the current production year.

(2) *Production of complying vehicles.* Each manufacturer shall report for the production year being reported on, and each preceding production year, to the extent that vehicles produced during the preceding years are treated under Standard No. 226 as having been produced during the production year being reported on, information on the number of passenger vehicles that meet the ejection mitigation requirements of Standard No. 226 (49 CFR 571.226).

**§ 585.106 Records.**

Each manufacturer shall maintain records of the Vehicle Identification Number for each vehicle for which information is reported under § 585.105 until December 31, 2020.

Issued on November 19, 2009.

**Stephen R. Kratzke,**

*Associate Administrator for Rulemaking.*

[FR Doc. E9-28177 Filed 12-1-09; 8:45 am]

BILLING CODE 4910-59-P